

ValveMate™ 8040

Quick Start Guide

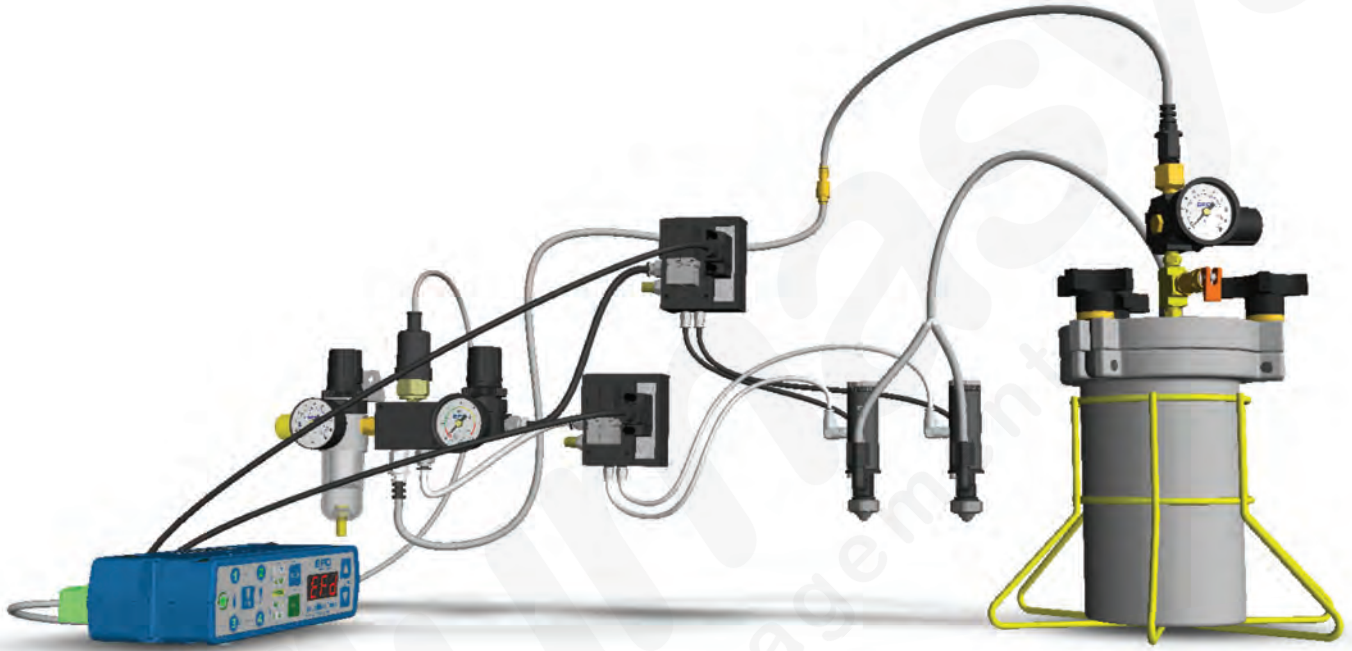

USA & Canada: 800.556.3484 or +1.401.431.7000
Europe: 0800 585733 or +44 (0) 1582 666334
Asia: +86 (21) 5854 2345
technical@nordsonefd.com www.nordsonefd.com

Electronic pdf files of Nordson EFD manuals are also available at www.nordsonefd.com

Unpack the ValveMate 8040.
 This is also a good time to activate the one-year warranty. Register online at www.nordsonefd.com/warranty/valves/one.

1

Mount the VM8040 and input power supply. The ValveMate can be mounted either over or under a cabinet or panel mounted using the bezel mount (included).

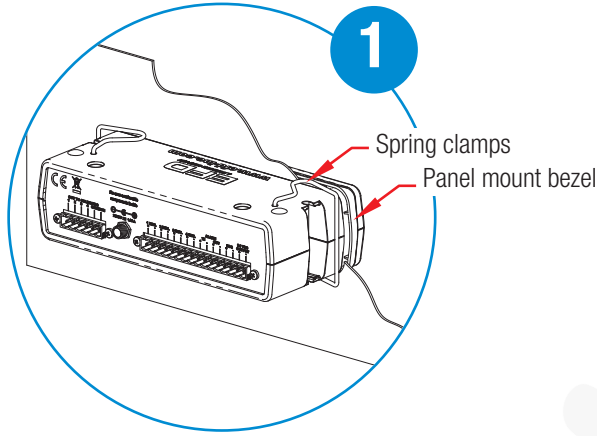

2

Install and connect the power supply. Connect the power supply cord to the ValveMate input connector. Secure with locking ring.

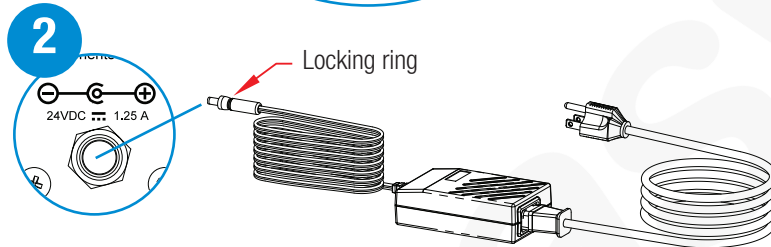

3

Install the air pressure regulator and air solenoids.

- A. Connect the plant air supply to the inlet of the filter regulator.
- B. Connect the solenoid cable between the solenoid and VM8040.

4

Connect the low air pressure sensor and tank low level switches (if low level float provided with reservoir) to ALARM IN. *See note below.

5

Connect the initiate I/O to the host machine control circuitry or to the bench initiate switch.

6

Install the spray valves.

- A. Mount the valves using appropriate mounting hardware.
- B. Connect the valve control air hoses to the appropriate solenoid outlets.

7

Connect the fluid reservoir.

- A. Connect the fluid reservoir air pressure regulator to the plant air supply using the air hose and fitting supplied.
 - B. Connect the reservoir fluid lines to the valves.
- Fill the fluid reservoir and secure the cover.

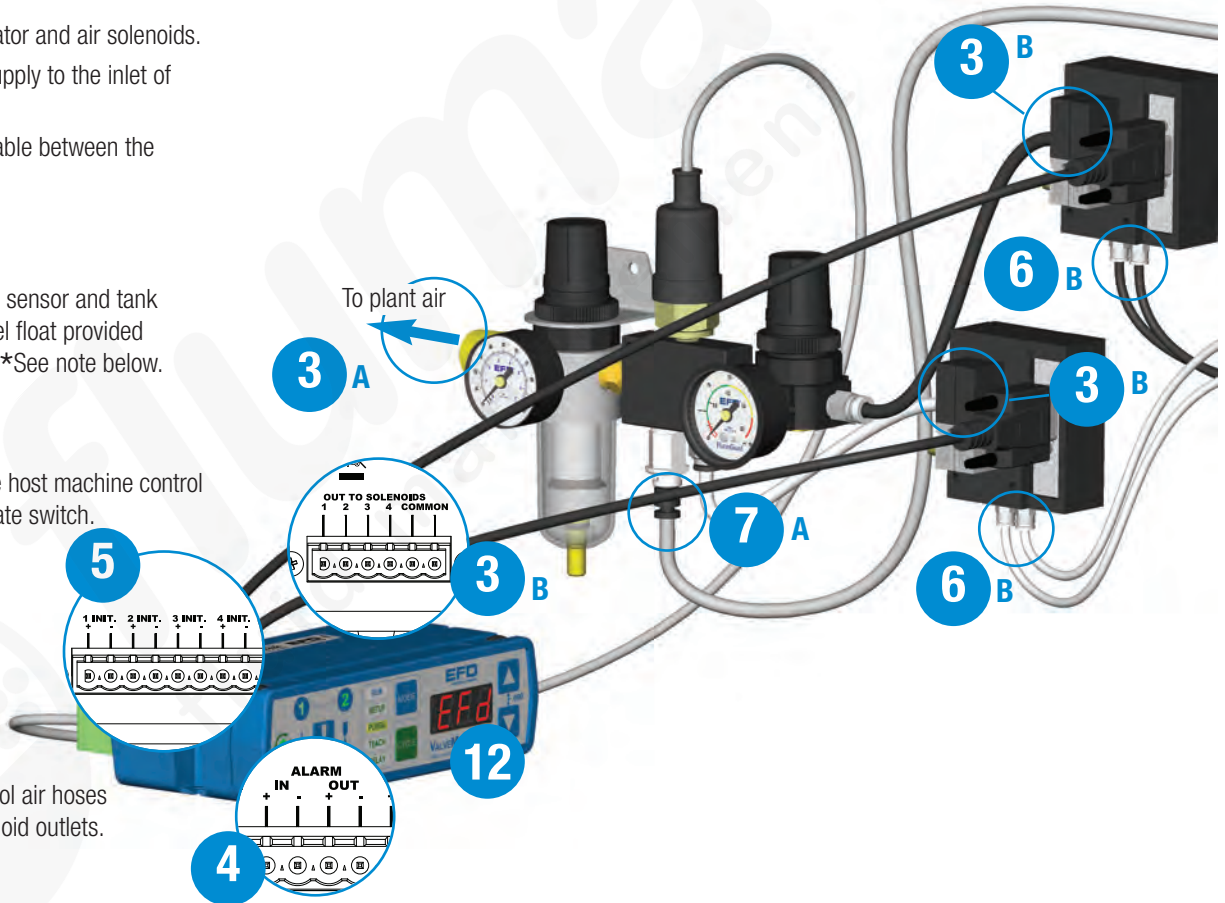

*Note: Wire additional normally closed alarm sensors in series and connect to the ALARM IN +/- terminals. If no alarm switch is used, the ALARM IN +/- terminals must have a jumper installed to disable the ALARM feature.

8

Final check list

- A. Air pressure to solenoid pack is set to 80 psi (5.5 bar).
- B. For spray valves, nozzle air regulator is set to 0 psi (0 bar).
- C. Solenoids and I/O are wired correctly.
- D. Valves and fluid reservoir are properly connected.
- E. Power to the ValveMate is on, and indicator lamps and LED are lit.

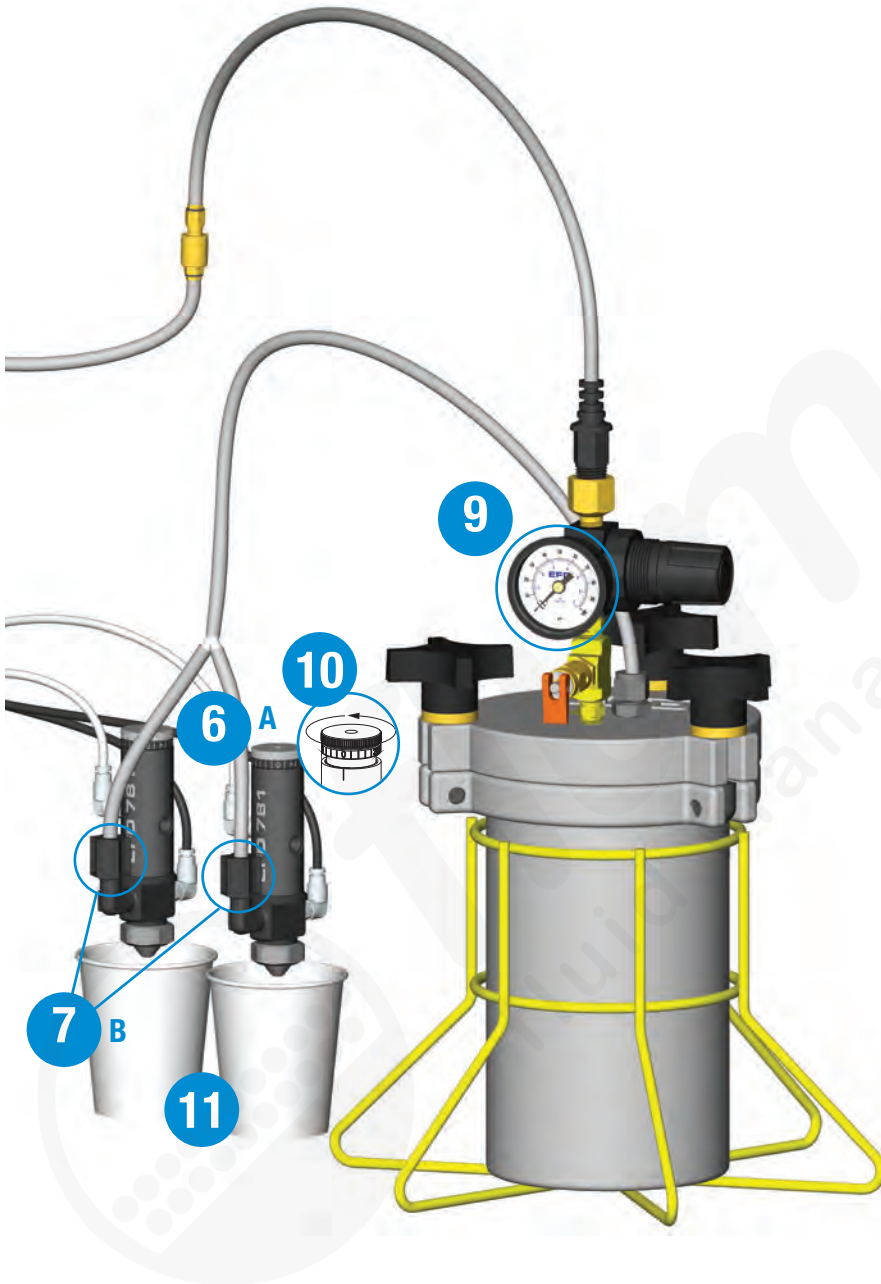

Valve open time is the primary control of deposit size. It is normal to end with different time settings for each valve.

9

Set the tank pressure to 5 psi (0.35 bar) for low viscosity fluids and 15 psi (1.03 bar) for medium viscosity fluids.

10

Set the spray valve stroke adjustment to 1/2 turn open. This is a starting point only.





11

Place a container under the spray valve(s).

- A. Using the MODE  button, place the VM8040 in **PURGE** mode.
- B. Press the **PURGE** button and hold until fluid flows and fluid lines are free of air. Then set the flow rate using the valve stroke setting and tank air pressure. Avoid high tank pressures with low stroke settings.
- C. Set the flow rate by counting drops to about one per second as a starting point.

12

Adjusting the spray

- A. Set the nozzle air pressure regulator to 10 psi.
- B. Press the **PURGE** button and observe the spray pattern.
- C. Using the spray valve stroke adjustment and tank air pressure, increase or decrease settings to arrive at the desired spray pattern.
- D. Using the MODE  button, place the controller into the **SETUP** mode.
- E. Press the SEL  button repeatedly until all valve indicator lights are lit.
- F. Enter a spray time of .050 seconds by pressing the up or down arrow next to the LED screen.
- G. With the container still under the valves, press the CYCLE  button to test the deposit amount.
- H. Increase or decrease the valve open time to arrive at the correct deposit size. To equalize all valves, press the SEL  button to highlight individual valves and use the valve open time to equalize the output.



Flumasys s.r.o.
info@flumasys.com

flumasys fluid management

液剤塗布システム Consistency 流体控制系统 Fluid dispensing systems 液剤吐出ノズル Dispense tips
ability Cartuchos Bezolowiowe 流体控制系统 Fluid dispensing systems 液剤吐出ノズル Dispense tips
ore Betrouwbaarheid Pájeci pasta Seringes Megbízhatóság Ago erogatore Vloeistoffen doseren 液剤吐出ノズル Dispense tips
vkoča Precyzja Qualidade 액체정량투출시스템 Silicone-vrij Dispense tips 一致性 Paste saldanti 一致性 Paste saldanti
バルブ吐出システム Fiabilidad Adagolótűk Paste saldanti 一致性 Paste saldanti 一致性 Paste saldanti
abilidad Serbatoi siringa Diszpenzálás Ventilátorok Injekciós gépek 一致性 Paste saldanti 一致性 Paste saldanti
der paste Valvole シリンジシステム カートリッジシステム Systemy dozujące 一致性 Paste saldanti 一致性 Paste saldanti
ensery Silikonfrei Sin silicóna Diszpenzálás Ventilátorok Injekciós gépek 一致性 Paste saldanti 一致性 Paste saldanti
Lötpaste 품질 Pasta de soldadura 디스펜싱팅 Bleifrei 一致性 Paste saldanti 一致性 Paste saldanti
ga 腕閥 Dosierventile Válvulas 디스펜싱팅 Bleifrei 一致性 Paste saldanti 一致性 Paste saldanti
d dispensing systems 可憐性 Affidabilità 一致性 Paste saldanti 一致性 Paste saldanti
ló rendszerek 可憐性 Affidabilità 一致性 Paste saldanti 一致性 Paste saldanti
コンフリー システム Regularité 一致性 Paste saldanti 一致性 Paste saldanti
ersysteme 신뢰 Regularité 一致性 Paste saldanti 一致性 Paste saldanti
Precizió Kartuschen 一致性 Paste saldanti 一致性 Paste saldanti

