

PICO® Touch Controller

Operating Manual



Electronic pdf files of Nordson EFD manuals are also available at www.nordsonefd.com



You have selected a reliable, high-quality dispensing system from Nordson EFD, the world leader in fluid dispensing. Nordson EFD dispensing systems are designed specifically for industrial dispensing and will provide you with years of trouble-free, productive service.

This manual will help you maximize the usefulness of your dispensing system.

Please spend a few minutes to become familiar with the controls and features. Follow our recommended testing procedures. Review the helpful information we have included, which is based on more than 50 years of industrial dispensing experience.

Most questions you will have are answered in this manual. However, if you need assistance, please do not hesitate to contact EFD or your authorized EFD distributor. Detailed contact information is provided on the last page of this document.

The Nordson EFD Pledge

Thank You!

You have just purchased the world's finest precision dispensing equipment.

I want you to know that all of us at Nordson EFD value your business and will do everything in our power to make you a satisfied customer.

If at any time you are not fully satisfied with our equipment or the support provided by your Nordson EFD Product Application Specialist, please contact me personally at 800.556.3484 (US), 401.431.7000 (outside US), or Srini.Subramanian@nordsonefd.com.

I guarantee that we will resolve any problems to your satisfaction.

Thanks again for choosing Nordson EFD.

Srini Subramanian

Srini Subramanian, General Manager

Contents

Contents	3
Introduction	5
Nordson EFD Product Safety Statement	6
Halogenated Hydrocarbon Solvent Hazards	7
High Pressure Fluids	7
Qualified Personnel.....	7
Intended Use	8
Regulations and Approvals.....	8
Personal Safety.....	8
Fire Safety.....	9
Preventive Maintenance	9
Important Disposable Component Safety Information.....	10
Action in the Event of a Malfunction.....	10
Disposal.....	10
Equipment-Specific Safety Information.....	11
Specifications.....	12
Operating Features.....	13
Front Panel.....	13
Back Panel.....	13
User Interface	14
Navigation and Screen Structure	14
Alarm Indication	14
Buttons and Icons	15
System Refresh.....	15
Entering Values.....	16
Flowchart of Menu Structure.....	17
HOME Screen	18
VALVE Screen.....	19
HEATERS Screen	21
WAVE PROFILE Screen.....	22
RAMP Screen.....	22
SETTINGS Screen.....	23
LCD SET Screen	24
FUNCTION LOCKOUT Screen.....	25
SYSTEM Screens.....	26
Installation	27
Unpack the System Components.....	27
Install the Valve and Controller	28
Setup and Programming Procedures.....	31
Connecting a Valve Initiate Signal	31
Changing the System (VALVE) Operating Mode.....	31
Adjusting the Valve Operating Parameters (PULSE, CYCLE, or COUNT).....	32
Switching Valve Power On or Off.....	32
Switching the Heater Control (MODE) to On, Off, or Remote.....	33
Viewing or Changing the Valve Heater Temperature / Temperature Setpoint.....	33
Connecting a Controller Status Monitoring Signal	34
Adjusting the Wave Profile.....	34
Viewing or Changing System Settings	35
Restoring the System to the Factory Default Settings	35
Managing Password Protection.....	36
Changing a SYSTEM or LOCKOUT Password	36
Resetting the SYSTEM and LOCKOUT Passwords.....	36
Managing Lockouts	37
Adjusting the LCD and Beep Settings.....	38
Calibrating the LCD	38
Setting the Language.....	39
Viewing the Controller and Valve Information.....	39

Continued on next page

Contents (continued)

Operation.....	40
Routine Startup.....	40
Purging the System	40
Clearing Alarms	41
Routine Shutdown	41
Part Number	42
Replacement Parts.....	42
Controller Components	42
Valve Extension Cables.....	43
Filter	43
Troubleshooting.....	44
Technical Data	46
Input / Output Port Pin Descriptions	46
I/O 1 15-Position D-Sub.....	46
I/O 2 25-Position D-Sub.....	48
Wiring Diagrams	50
PICO Touch Controller Inputs	50
PICO Touch Controller Outputs	51
PICO Touch Controller and PICO Controller 2+2-XCH-V3	52
Appendix A, Remotely Operating the Controller.....	53



flumma
fluid management

Introduction

This manual provides installation, setup, programming, operation, and service information for the Nordson EFD PICO Touch controller. The Touch controller controls the operation of the Nordson EFD PICO Pulse™ valve. Refer to the Pulse valve operating manual for detailed information on the valve.

The Touch controller provides an intuitive touchscreen interface for easy set up and operation of the Pulse valve. Through the touchscreen interface, you can:

- Control the operation of the valve, including open and close parameters and stroke control.
- Set the valve operating temperature.
- Fine-tune the dispensing performance by selecting preset ramp profiles or using custom profiles.
- View or change all controller settings.

The PICO Touch controller also allows external control of all parameters through a personal computer (PC).

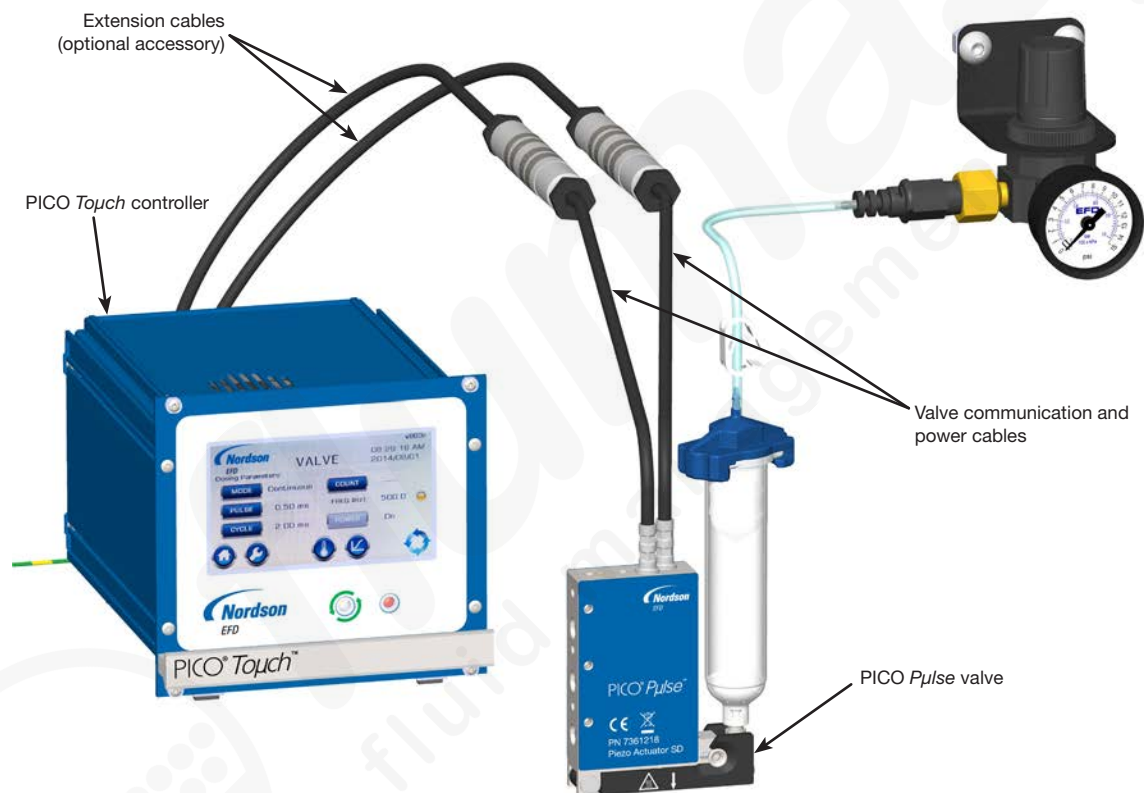

Typical PICO Touch controller and Pulse valve system setup

Nordson EFD Product Safety Statement

WARNING

The safety message that follows has a WARNING level hazard.
Failure to comply could result in death or serious injury.



ELECTRIC SHOCK

Risk of electric shock. Disconnect power before removing covers and/or disconnect, lock out, and tag switches before servicing electrical equipment. If you receive even a slight electrical shock, shut down all equipment immediately. Do not restart the equipment until the problem has been identified and corrected.

CAUTION

The safety messages that follow have a CAUTION level hazard.
Failure to comply may result in minor or moderate injury.



READ MANUAL

Read manual for proper use of this equipment. Follow all safety instructions. Task- and equipment-specific warnings, cautions, and instructions are included in equipment documentation where appropriate. Make sure these instructions and all other equipment documents are accessible to persons operating or servicing equipment.



MAXIMUM AIR PRESSURE

Unless otherwise noted in the product manual, the maximum air input pressure is 7.0 bar (100 psi). Excessive air input pressure may damage the equipment. Air input pressure is intended to be applied through an external air pressure regulator rated for 0 to 7.0 bar (0 to 100 psi).



RELEASE PRESSURE

Release hydraulic and pneumatic pressure before opening, adjusting, or servicing pressurized systems or components.



BURNS

Hot surfaces! Avoid contact with the hot metal surfaces of heated components. If contact can not be avoided, wear heat-protective gloves and clothing when working around heated equipment. Failure to avoid contact with hot metal surfaces can result in personal injury.

Nordson EFD Product Safety Statement (continued)

Halogenated Hydrocarbon Solvent Hazards

Do not use halogenated hydrocarbon solvents in a pressurized system that contains aluminum components. Under pressure, these solvents can react with aluminum and explode, causing injury, death, or property damage. Halogenated hydrocarbon solvents contain one or more of the following elements.

Element	Symbol	Prefix
Fluorine	F	“Fluoro-”
Chlorine	Cl	“Chloro-”
Bromine	Br	“Bromo-”
Iodine	I	“Iodo-”

Check the Safety Data Sheet (SDS) or contact your material supplier for more information. If you must use halogenated hydrocarbon solvents, contact your EFD representative for compatible EFD components.

High Pressure Fluids

High pressure fluids, unless they are safely contained, are extremely hazardous. Always release fluid pressure before adjusting or servicing high pressure equipment. A jet of high pressure fluid can cut like a knife and cause serious bodily injury, amputation, or death. Fluids penetrating the skin can also cause toxic poisoning.

WARNING

Any injury caused by high pressure liquid can be serious. If you are injured or even suspect an injury:

- Go to an emergency room immediately.
- Tell the doctor that you suspect an injection injury.
- Show the doctor the following note.
- Tell the doctor what kind of material you were dispensing.

Medical Alert — Airless Spray Wounds: Note to Physician

Injection in the skin is a serious traumatic injury. It is important to treat the injury surgically as soon as possible. Do not delay treatment to research toxicity. Toxicity is a concern with some exotic coatings injected directly into the bloodstream.

Qualified Personnel

Equipment owners are responsible for making sure that EFD equipment is installed, operated, and serviced by qualified personnel. Qualified personnel are those employees or contractors who are trained to safely perform their assigned tasks. They are familiar with all relevant safety rules and regulations and are physically capable of performing their assigned tasks.

Nordson EFD Product Safety Statement (continued)

Intended Use

Use of EFD equipment in ways other than those described in the documentation supplied with the equipment may result in injury to persons or damage to property. Some examples of unintended use of equipment include:

- Using incompatible materials.
- Making unauthorized modifications.
- Removing or bypassing safety guards or interlocks.
- Using incompatible or damaged parts.
- Using unapproved auxiliary equipment.
- Operating equipment in excess of maximum ratings.
- Operating equipment in an explosive atmosphere.

Regulations and Approvals

Make sure all equipment is rated and approved for the environment in which it is used. Any approvals obtained for Nordson EFD equipment will be voided if instructions for installation, operation, and service are not followed. If the equipment is used in a manner not specified by Nordson EFD, the protection provided by the equipment may be impaired.

Personal Safety

To prevent injury, follow these instructions:

- Do not operate or service equipment unless you are qualified.
- Do not operate equipment unless safety guards, doors, and covers are intact and automatic interlocks are operating properly. Do not bypass or disarm any safety devices.
- Keep clear of moving equipment. Before adjusting or servicing moving equipment, shut off the power supply and wait until the equipment comes to a complete stop. Lock out power and secure the equipment to prevent unexpected movement.
- Make sure spray areas and other work areas are adequately ventilated.
- When using a syringe barrel, always keep the dispensing end of the tip pointing towards the work and away from the body or face. Store syringe barrels with the tip pointing down when they are not in use.
- Obtain and read the Safety Data Sheet (SDS) for all materials used. Follow the manufacturer's instructions for safe handling and use of materials and use recommended personal protection devices.
- Be aware of less-obvious dangers in the workplace that often cannot be completely eliminated, such as hot surfaces, sharp edges, energized electrical circuits, and moving parts that cannot be enclosed or otherwise guarded for practical reasons.
- Know where emergency stop buttons, shutoff valves, and fire extinguishers are located.
- Wear hearing protection to protect against hearing loss that can be caused by exposure to vacuum exhaust port noise over long periods of time.

Nordson EFD Product Safety Statement (continued)

Fire Safety

To prevent a fire or explosion, follow these instructions:

- Shut down all equipment immediately if you notice static sparking or arcing. Do not restart the equipment until the cause has been identified and corrected.
- Do not smoke, weld, grind, or use open flames where flammable materials are being used or stored.
- Do not heat materials to temperatures above those recommended by the manufacturer. Make sure heat monitoring and limiting devices are working properly.
- Provide adequate ventilation to prevent dangerous concentrations of volatile particles or vapors. Refer to local codes or the SDS for guidance.
- Do not disconnect live electrical circuits when working with flammable materials. Shut off power at a disconnect switch first to prevent sparking.
- Know where emergency stop buttons, shutoff valves, and fire extinguishers are located.

Preventive Maintenance

As part of maintaining continuous trouble-free use of this product, Nordson EFD recommends the following simple preventive maintenance checks:

- Periodically inspect tube-to-fitting connections for proper fit. Secure as necessary.
- Check tubing for cracks and contamination. Replace tubing as necessary.
- Check all wiring connections for looseness. Tighten as necessary.
- Clean: If a front panel requires cleaning, use a clean, soft, damp rag with a mild detergent cleaner. DO NOT USE strong solvents (MEK, acetone, THF, etc.) as they will damage the front panel material.
- Maintain: Use only a clean, dry air supply to the unit. The equipment does not require any other regular maintenance.
- Test: Verify the operation of features and the performance of equipment using the appropriate sections of this manual. Return faulty or defective units to Nordson EFD for replacement.
- Use only replacement parts that are designed for use with the original equipment. Contact your Nordson EFD representative for information and advice.

Nordson EFD Product Safety Statement (continued)

Important Disposable Component Safety Information

All Nordson EFD disposable components, including syringe barrels, cartridges, pistons, tip caps, end caps, and dispense tips, are precision engineered for one-time use. Attempting to clean and re-use components will compromise dispensing accuracy and may increase the risk of personal injury.

Always wear appropriate protective equipment and clothing suitable for your dispensing application and adhere to the following guidelines:

- Do not heat syringe barrels or cartridges to a temperature greater than 38° C (100° F).
- Dispose of components according to local regulations after one-time use.
- Do not clean components with strong solvents (MEK, acetone, THF, etc.).
- Clean cartridge retainer systems and barrel loaders with mild detergents only.
- To prevent fluid waste, use Nordson EFD SmoothFlow™ pistons.

Action in the Event of a Malfunction

If a system or any equipment in a system malfunctions, shut off the system immediately and perform the following steps:

1. Disconnect and lock out system electrical power. If using hydraulic and pneumatic shutoff valves, close and relieve pressure.
2. For Nordson EFD air-powered dispensers, remove the syringe barrel from the adapter assembly. For Nordson EFD electro-mechanical dispensers, slowly unscrew the barrel retainer and remove the barrel from the actuator.
3. Identify the reason for the malfunction and correct it before restarting the system.

Disposal

Dispose of equipment and materials used in operation and servicing according to local codes.

Nordson EFD Product Safety Statement (continued)

Equipment-Specific Safety Information

The following safety information is specific to the Nordson EFD *Touch* controller.

Intended Use

- This equipment is for indoor use only.
- Use the *Touch* controller only in conjunction with its associated power cable and, if needed, its associated extension cable.
- Do not open the *Touch* controller.

Unintended Fluid Release

- Prior to initial operation, check to see if fluid flows out of a valve that is turned off even when no fluid pressure is being applied. If this occurs, it may be because the fluid reservoir is positioned higher than the valve, in which case hydrostatic pressure causes the fluid to flow out of a valve that is not closed. Position the fluid reservoir low enough such that no fluid leaks from the valve when the valve is shut off.
- In the case of damage to the piezo actuator or the *Touch* controller, the valve may transition from a CLOSED to an OPEN condition, which can cause fluid release. Nordson EFD recommends continually monitoring the status signal of the *Touch* controller and immediately and automatically bleeding the fluid reservoir if these signals indicate an error.
- Before connecting or disconnecting a valve cable, release fluid pressure and disconnect and lock out power to the *Touch* controller.

Specifications

NOTE: Specifications and technical details are subject to engineering change without prior notification.

Item	Specification
Cabinet size	14.2W x 13.3H x 16.8D cm (28 Hp x 3U) 5.6w x 5.25H x 6.6D"
Weight	2.6 kg (5.5 lb)
Material	Aluminum / steel
Input AC (to power supply)	100–240 VAC +/-10%, 50–60 Hz, 2 Amp
Output DC (from power supply)	24 VDC, 6.25 Amp
Internal voltage	150 VDC, 24 VDC, 5 VDC, and 3.3 VDC
Heater output voltage	24 VDC, 30 W maximum
Feedback circuit	0–24 VDC
Initiate circuit	15–24 VDC (must be a clean, bounce-free signal)
Heater outputs	Setpoint range: 0–100° C; 0.1° C increments Temperature input type at valve: RTD Indication accuracy: ±1° C Sample rate: 60 per second Control method: PID NOTE: No valve cooling is possible.
Cycle rate	Valve-dependent
Time range	100 µs to 9.9999 s (depending on the open profile time)
Ambient operating conditions	Temperature: 5–45° C (41–133° F) Humidity: 85% relative humidity at 30° C (86° F), non-condensing Height above sea level: 2000 m (6,562 ft) maximum Indoor use only
Product classification	Installation category II Pollution degree 2
Approvals	CE, RoHS, WEEE, and China ROHS compliant

RoHS标准相关声明 (China RoHS Hazardous Material Declaration)

产品名称 Part Name	有害物质及元素 Toxic or Hazardous Substances and Elements					
	铅 Lead (Pb)	汞 Mercury (Hg)	镉 Cadmium (Cd)	六价铬 Hexavalent Chromium (Cr6)	多溴联苯 Polybrominated Biphenyls (PBB)	多溴联苯醚 Polybrominated Diphenyl Ethers (PBDE)
外部接口 External Electrical Connectors	X	0	0	0	0	0
<p>0: 表示该产品所含有的危险成分或有害物质含量依照EIP-A, EIP-B, EIP-C 的标准低于SJ/T11363-2006 限定要求。 Indicates that this toxic or hazardous substance contained in all the homogeneous materials for this part, according to EIP-A, EIP-B, EIP-C is below the limit requirement in SJ/T11363-2006.</p> <p>X: 表示该产品所含有的危险成分或有害物质含量依照EIP-A, EIP-B, EIP-C 的标准高于SJ/T11363-2006 限定要求。 Indicates that this toxic or hazardous substance contained in all the homogeneous materials for this part, according to EIP-A, EIP-B, EIP-C is above the limit requirement in SJ/T11363-2006.</p>						

WEEE Directive



This equipment is regulated by the European Union under WEEE Directive (2012/19/EU). Refer to www.nordsonefd.com/WEEE for information about how to properly dispose of this equipment.

Operating Features

Front Panel

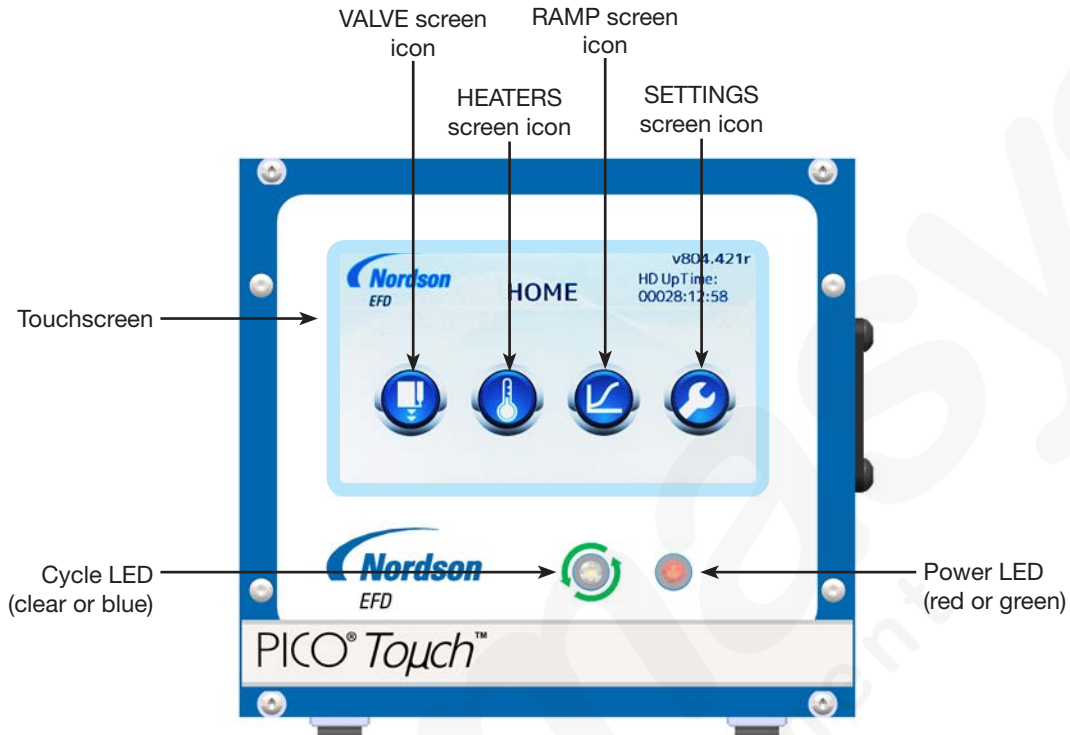

Back Panel

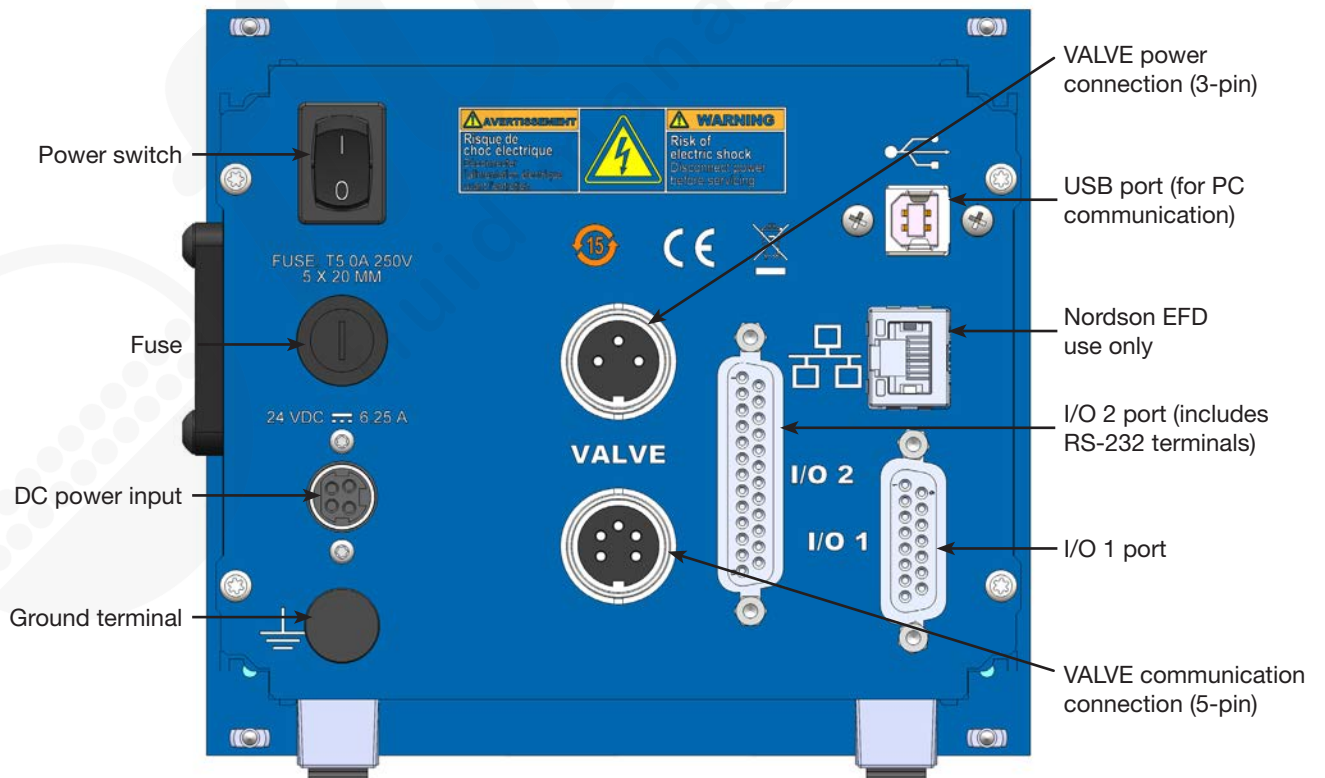

User Interface

The controller is operated through an easy-to-use touchscreen interface. This section provides an overview of the user interface and all the controller's screens and menus.

Navigation and Screen Structure

All system controls are accessed through the icons and buttons on the touchscreen. Each screen includes icons that allow you to jump quickly to other main screens. Each screen also shows the current LCD display version and the system UpTime, which is an indicator of how long the controller has been active or operational. The UpTime is specifically used to track when alarm conditions occur in the controller.

Title bar area shows:

- LCD version
- Module / screen name
- Up Time: How long the controller has been ON.

Button area

Quick navigation area for easy access to other modules / screens

Structure of a Touch controller screen (VALVE screen shown; LCD version number and UpTime values are only examples)

Alarm Indication

The title bar blinks red anytime an alarm condition is detected, regardless of the type of alarm. For example, if a POWER alarm occurs when the VALVE screen is open, the title bar blinks red even though the alarm is not a valve-related alarm. To view the alarm type, touch the title bar.



Title bar blinks red anytime an alarm condition is detected, regardless of the alarm type. Touch the title bar to view the alarm.

Example of the alarm screen





















User Interface (continued)

Buttons and Icons

System selections are made by pressing a button or an icon. Buttons change color based on their status, as shown in the following table.

Button	Button Color	Status
	Blue	Not selected
	Pale blue	Selected
	Light gray	Disabled

All non-textual system controls are shown in the legend below. Screen names are shown in all-capital letters. This legend is present on the pages of this manual that include programming procedures.

ABOUT 	CALENDAR  CLOCK SET	OK (check) 	LANGUAGE 	RAMP 
Backspace 	Cancel 	HEATERS 	LOCKOUTS 	SETTINGS 
LCD SETTINGS 	Decimal Point 	HOME 	PASSWORDS 	SYSTEM 
CYCLE 	Decrement 	Increment 	PURGE 	VALVE 

System Refresh

 A system refresh occurs upon power on or when settings are changed remotely. When the system refreshes, an hourglass appears on the touchscreen and no user input is accepted. Refresh takes just a few seconds.

User Interface (continued)

Entering Values

A numeric or alphanumeric keypad appears whenever data entry is required, such as for password entry.

CANCEL

Press to discard any entered data and return to the previous screen

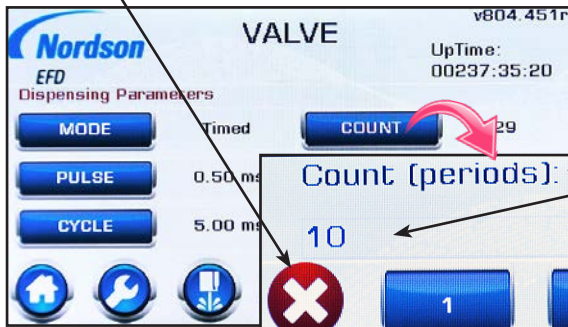

Current field name

Current field value

BACKSPACE

Press to delete one character.

INCREMENT (+) or DECREMENT (-)

Press to increase or decrease in the current field value (increments vary based on the setting being modified).



OK (check)

Press to submit the current field value

CLR

Press to clear the current field value

Example of a numeric data entry screen

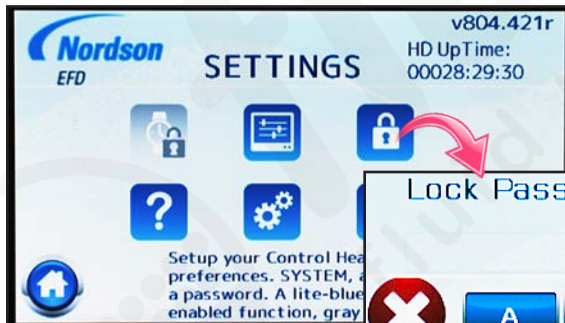

NUMERIC ENTRY

Press to change to the number keypad

UNDERSCORE

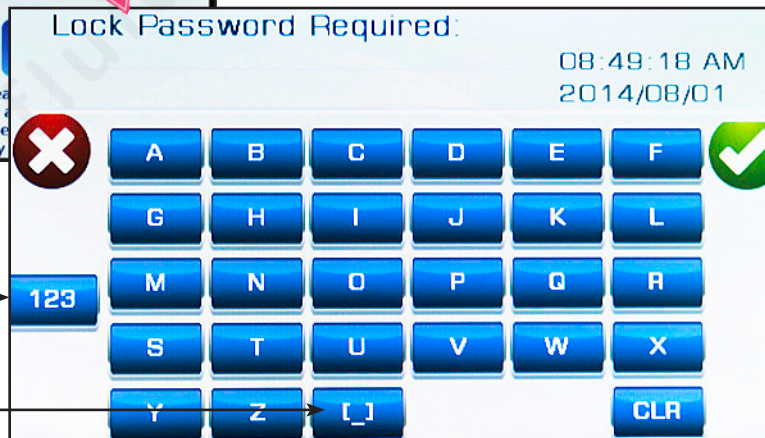

Example of an alphabetic data entry screen

HOME Screen

All secondary and tertiary screens are accessed through the HOME screen.

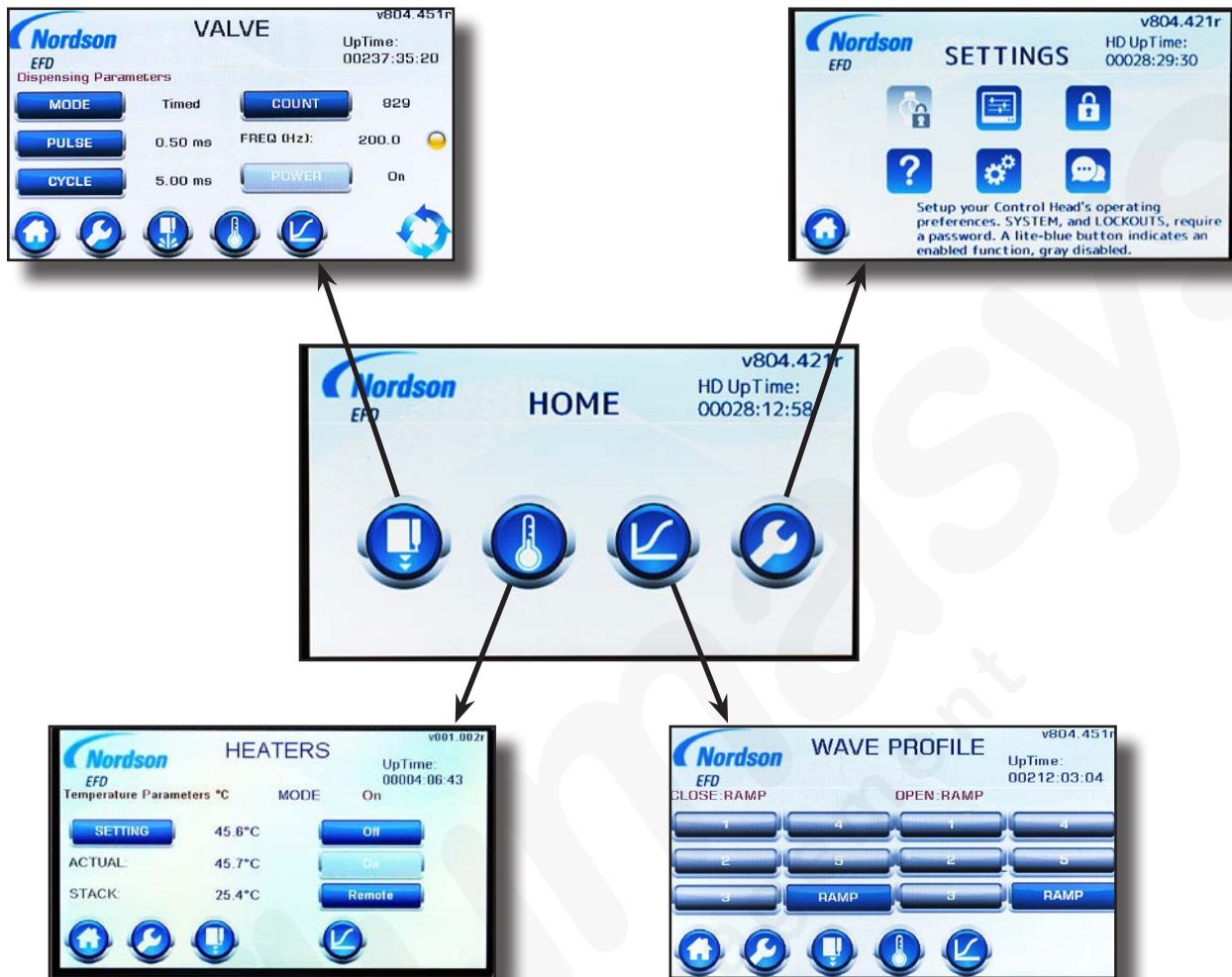

Icon	Description
VALVE	Opens the VALVE screen. Refer to "VALVE Screen" on page 19.
HEATERS	Opens the HEATERS screen. Refer to "HEATERS Screen" on page 21.
RAMP	Opens the WAVE PROFILE screen. The WAVE PROFILE screen provides access to the RAMP and RAMP GRAPH screens. Refer to "WAVE PROFILE Screen" on page 22.
SETTINGS	Opens the SETTINGS screen. The SETTINGS screen provides access to all system-related setup screens. Refer to "SETTINGS Screen" on page 23.

VALVE Screen

The VALVE screen is used to change the operating mode, enter valve dispensing parameters, and control valve power.

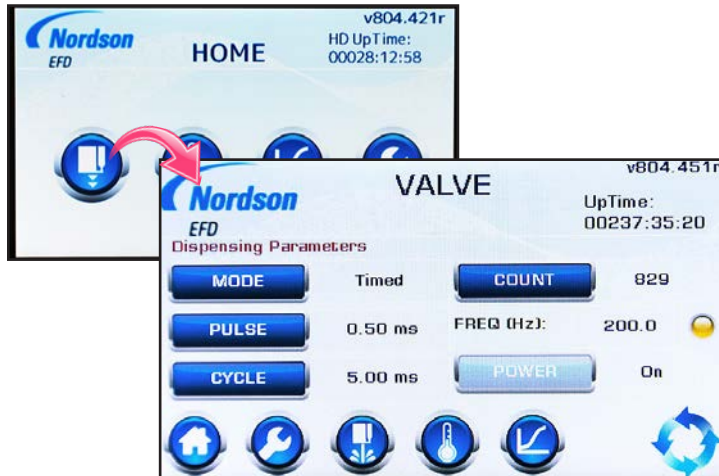



Button or Icon	Description								
MODE	Sets the system operating mode.								
	<table border="1"> <thead> <tr> <th>Mode</th> <th>Description</th> </tr> </thead> <tbody> <tr> <td>Timed</td> <td>In the Timed mode, the valve cycles according to the settings for PULSE (valve open time), CYCLE (time between deposits), and COUNT (number of deposits) for each valve initiate signal.</td> </tr> <tr> <td>Continuous</td> <td>In the Continuous mode, the valve cycles according to the settings for PULSE (valve open time) and CYCLE (time between deposits) for as long as the valve initiate signal is active, ignoring any setting for COUNT (number of deposits). NOTE: If the system is latched on to a signal in the Continuous mode, you cannot change screens.</td> </tr> <tr> <td>External</td> <td>In the External mode, the controller operates as a slave to an input signal and thus no longer generates the timing signals required to drive the valve. This mode is typically used with a device such as the PICO 2+2-XCH-V3 controller for pattern generation. NOTE: This selection is available only when SHOW VALVE EXTERNAL is toggled ON via the SYSTEM screen. Refer to SHOW VALVE EXTERNAL under "SYSTEM Screens" on page 26.</td> </tr> </tbody> </table>	Mode	Description	Timed	In the Timed mode, the valve cycles according to the settings for PULSE (valve open time), CYCLE (time between deposits), and COUNT (number of deposits) for each valve initiate signal.	Continuous	In the Continuous mode, the valve cycles according to the settings for PULSE (valve open time) and CYCLE (time between deposits) for as long as the valve initiate signal is active, ignoring any setting for COUNT (number of deposits). NOTE: If the system is latched on to a signal in the Continuous mode, you cannot change screens.	External	In the External mode, the controller operates as a slave to an input signal and thus no longer generates the timing signals required to drive the valve. This mode is typically used with a device such as the PICO 2+2-XCH-V3 controller for pattern generation. NOTE: This selection is available only when SHOW VALVE EXTERNAL is toggled ON via the SYSTEM screen. Refer to SHOW VALVE EXTERNAL under "SYSTEM Screens" on page 26.
	Mode	Description							
	Timed	In the Timed mode, the valve cycles according to the settings for PULSE (valve open time), CYCLE (time between deposits), and COUNT (number of deposits) for each valve initiate signal.							
Continuous	In the Continuous mode, the valve cycles according to the settings for PULSE (valve open time) and CYCLE (time between deposits) for as long as the valve initiate signal is active, ignoring any setting for COUNT (number of deposits). NOTE: If the system is latched on to a signal in the Continuous mode, you cannot change screens.								
External	In the External mode, the controller operates as a slave to an input signal and thus no longer generates the timing signals required to drive the valve. This mode is typically used with a device such as the PICO 2+2-XCH-V3 controller for pattern generation. NOTE: This selection is available only when SHOW VALVE EXTERNAL is toggled ON via the SYSTEM screen. Refer to SHOW VALVE EXTERNAL under "SYSTEM Screens" on page 26.								
⚠ CAUTION									
Because the controller does not generate timing signals in the external mode, take care to not exceed the maximum operating parameters of the connected valve. In addition, the time setting of any external signal used to drive the valve must be greater than the RAMP OPEN profile time setting (refer to "WAVE PROFILE Screen" on page 22). Exceeding timing and valve operational parameters can result in overall loss of performance.									
PULSE	Sets how long the valve opens (in milliseconds). Default: 10 (ms) Range: Depends on the open profile time and the type of valve being used; as low as 100 μ s possible								
CYCLE	Sets the amount of time between deposits (in milliseconds). Default: 30 (ms) Range: 2 (ms) to 9.9999 (s) typical (minimum setting depends on open and close profile times)								

Continued on next page

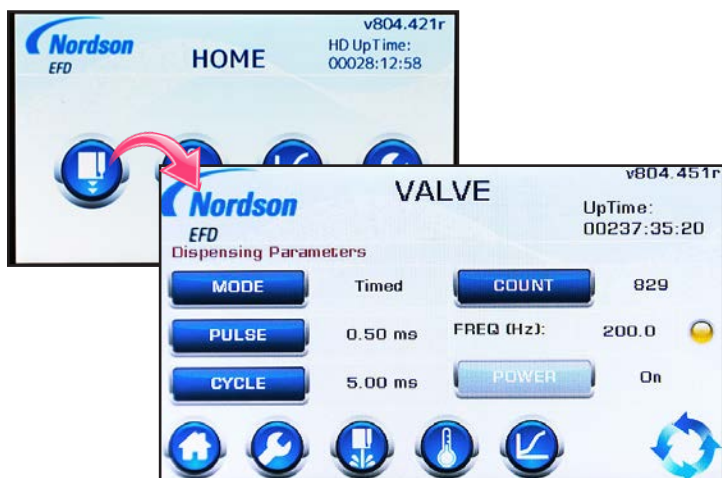
VALVE Screen (continued)



Button or Icon	Description								
COUNT	<p>Sets the number of deposits the valve dispenses per valve initiate cycle.</p> <p>Default: 1 Range: 00001–65535</p>								
FREQ (Hz) (Non-editable)	<p>Provides a color indication to show how fast the valve is operating (in Hz) at the selected settings; a lower frequency indicates slower operation; a higher frequency indicates faster operation.</p> <table border="1"> <thead> <tr> <th>Color</th> <th>Description</th> </tr> </thead> <tbody> <tr> <td>Green</td> <td>Safe operating frequency</td> </tr> <tr> <td>Yellow</td> <td>Caution—exceeding maximum frequency limits</td> </tr> <tr> <td>Red</td> <td>At the border of maximum operating frequency</td> </tr> </tbody> </table>	Color	Description	Green	Safe operating frequency	Yellow	Caution—exceeding maximum frequency limits	Red	At the border of maximum operating frequency
Color	Description								
Green	Safe operating frequency								
Yellow	Caution—exceeding maximum frequency limits								
Red	At the border of maximum operating frequency								
POWER	<p>Sets whether a valve initiate signal is processed and also closes (applies voltage to) the valve. Valve initiate signals are processed only when valve POWER is ON. By default, valve POWER is ON when the controller is switched on.</p> <p>NOTE: The valve is normally open and power must be applied to close it. Always turn the valve ON before applying fluid and air pressure; otherwise, the valve will leak.</p> <table border="1"> <tbody> <tr> <td>ON</td> <td>Valve closed</td> </tr> <tr> <td>OFF</td> <td>Valve open</td> </tr> </tbody> </table>	ON	Valve closed	OFF	Valve open				
ON	Valve closed								
OFF	Valve open								
 (PURGE)	<p>Purges the system.</p> <p>NOTE: The PURGE icon:</p> <ul style="list-style-type: none"> • Is present only on the VALVE screen. • Is visible only when valve POWER is ON. • Functions only if the valve is not dispensing. • Is disabled if an alarm condition exists. 								
 (CYCLE)	<p>Initiates a dispense cycle. How the system responds varies depending on the mode. Refer to "Changing the System (VALVE) Operating Mode" on page 31 for more detailed information.</p> <p>NOTE: The CYCLE icon:</p> <ul style="list-style-type: none"> • Is present only on the VALVE screen. • Is disabled if an alarm condition exists. 								

HEATERS Screen

The HEATERS screen is used to turn heater control on or off, change the heater control to remote operation, and to enter a temperature setpoint for the valve heater.

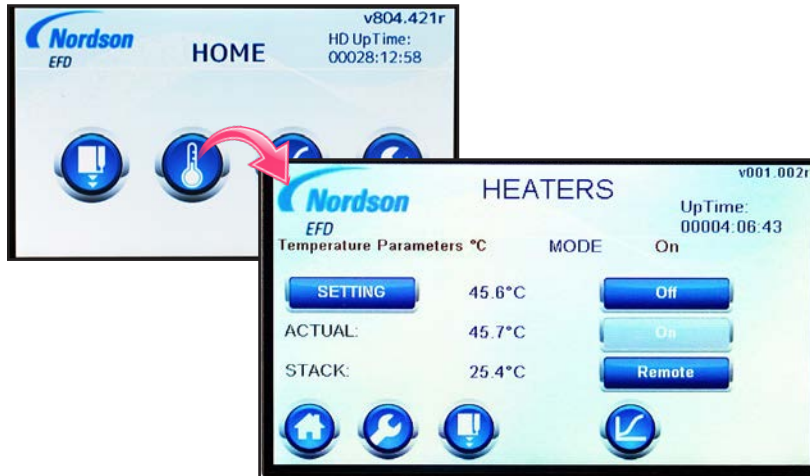

Item or Button	Description	
MODE	Shows the current heater control mode.	
	Mode	Description
	OFF	Heater control is switched OFF.
	ON	Heater control is switched ON.
	REMOTE	The heater control follows the remote input supplied through the I/O connector. Refer to "Input / Output Port Pin Descriptions" on page 46.
SETTING	Sets the heater temperature in degrees C or degrees F.	
ACTUAL (Non-editable)	Shows the actual temperature of the heater.	
STACK (Non-editable)	If toggled on, shows the actual temperature of the piezo actuator stack. Refer to the SYSTEM screen parameters under "SYSTEM Screens" on page 26 to toggle the STACK display.	

WAVE PROFILE Screen

The valve actuation signal, known as ramp, can be illustrated as a wave pattern. The rise and fall of the actuation signal, shown as a rise and fall in the wave pattern, affects the material deposit. The Touch controller can create a ramp profile for both the valve open (fall) and valve close (rise) signals based on settings entered on the RAMP screen.

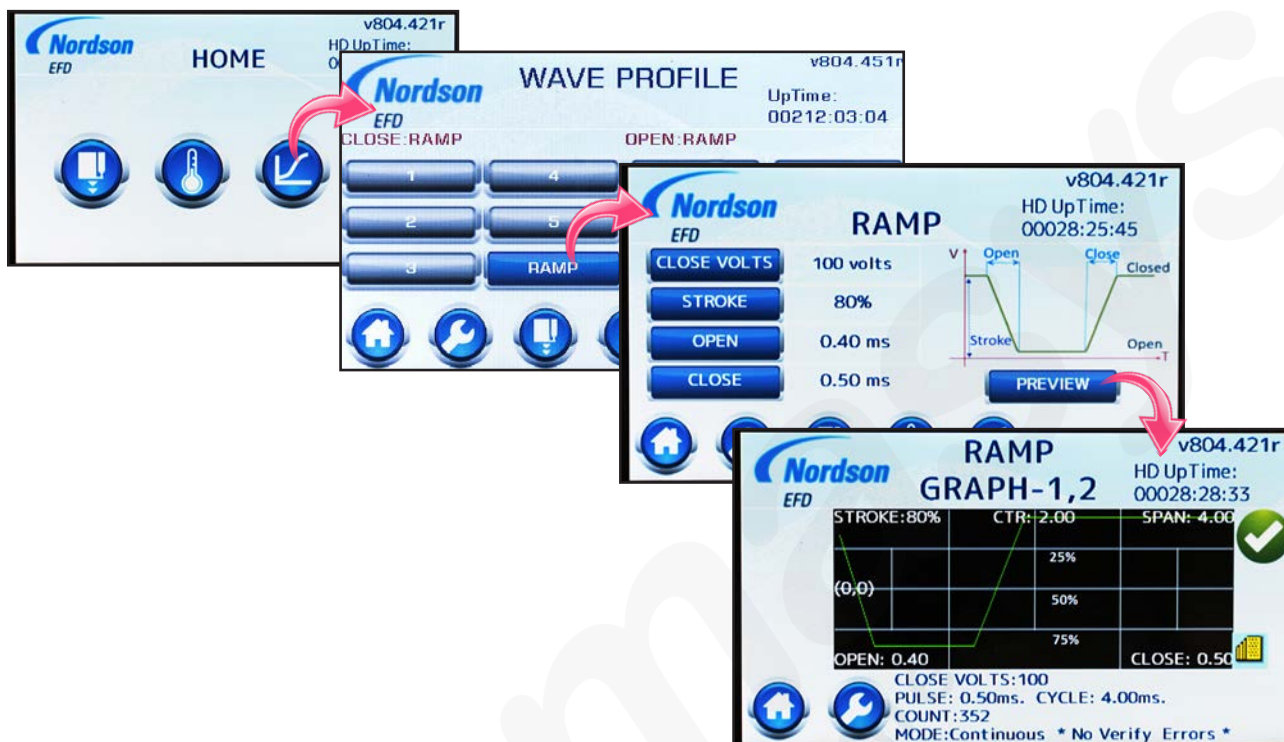

Button	Description
CLOSE (1, 2, 3, 4, 5, or RAMP)	Sets how fast the valve actuation signal rises. When RAMP is selected, the system creates a CLOSE profile based on the settings entered on the RAMP screen. Refer to "Adjusting the Wave Profile" on page 34 for more information.
OPEN (1, 2, 3, 4, 5, or RAMP)	Sets how fast the valve actuation signal falls. When RAMP is selected, the system creates an OPEN profile based on the settings entered on the RAMP screen. Refer to "Adjusting the Wave Profile" on page 34 for more information.
NOTE: CLOSE 1-5 and OPEN 1-5 are factory disabled (locked out). Obtain assistance from EFD Technical Services to change these settings.	

RAMP Screen

Button	Description
CLOSE VOLTS	Sets the voltage to close the valve. The higher the voltage, the greater the sealing force applied.
STROKE	Sets the voltage for each initiate cycle. For example, a CLOSE VOLTS setting of 120V and a STROKE setting of 50% means that when the valve actuates, the voltage changes from 120V to 60V and then back to 120V, as shown by the wave profile RAMP GRAPH, which you can view by pressing PREVIEW.
NOTE: To ensure that the valve operates within its safe operating limits, the controller may automatically adjust the CLOSE VOLTS and STROKE settings depending on the type of valve connected.	
OPEN	Sets how fast the valve opens. The range is valve-dependent, but typically 200–500 μ s.
CLOSE	Sets how fast the valve closes. The range is valve-dependent, but typically 200–2,000 μ s.
PREVIEW	Opens the RAMP GRAPH screen, which displays a visual representation of the wave profile based on the settings entered for OPEN and CLOSE on the RAMP screen. NOTE: The PREVIEW screen shows a wave profile only for the CLOSE: RAMP and OPEN: RAMP profiles. It does not provide a wave profile for any custom profiles (CLOSE 1-5 and OPEN 1-5).

SETTINGS Screen

The SETTINGS screen provides access to system-level information, settings, and functions.

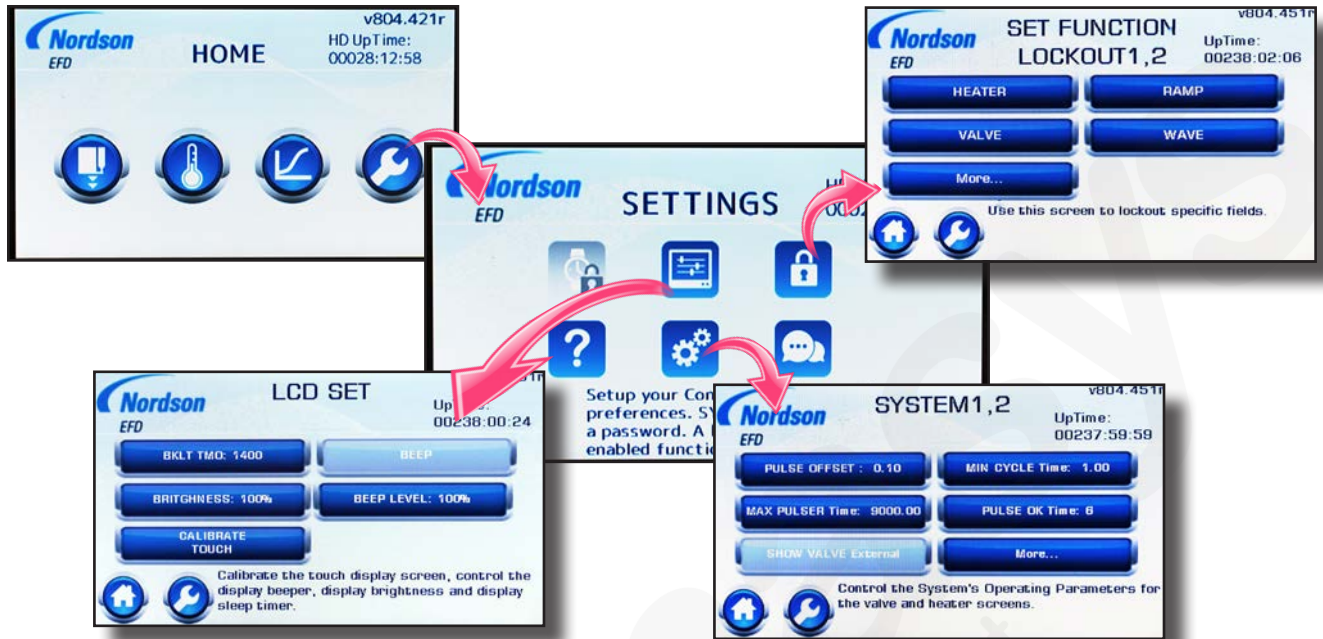

Icon	Description										
CALENDAR CLOCK SET	Sets the system date, time, date format, and time format. NOTE: CALENDAR CLOCK SET is currently non-editable. It will be available in a future release.										
ABOUT	Provides the following system information: <table border="0" style="width: 100%;"> <tr> <td>Model</td> <td>Serial Number</td> </tr> <tr> <td>LCD Version Number</td> <td>Firmware Version</td> </tr> <tr> <td>Date</td> <td>LCD Serial Number</td> </tr> <tr> <td>Valve Firmware Version</td> <td>Valve Serial Number</td> </tr> <tr> <td>Valve Model Number</td> <td>Failure Count (the number of alarms recorded since the system has been active; see NOTES)</td> </tr> </table> <p>Shot Count (the total number of deposits)</p> <p>NOTES:</p> <ul style="list-style-type: none"> Alarm conditions and when they occurred can be extracted via the serial command "ralr." Refer to "Appendix A, Remotely Operating the Controller" on page 53. For screen captures, refer to "Viewing the Controller and Valve Information" on page 39. 	Model	Serial Number	LCD Version Number	Firmware Version	Date	LCD Serial Number	Valve Firmware Version	Valve Serial Number	Valve Model Number	Failure Count (the number of alarms recorded since the system has been active; see NOTES)
Model	Serial Number										
LCD Version Number	Firmware Version										
Date	LCD Serial Number										
Valve Firmware Version	Valve Serial Number										
Valve Model Number	Failure Count (the number of alarms recorded since the system has been active; see NOTES)										
LANGUAGE	Sets the user interface language. Refer to the SET LANGUAGE screens for available languages. NOTE: For screen captures, refer to "Setting the Language" on page 39.										

LCD SET Screen

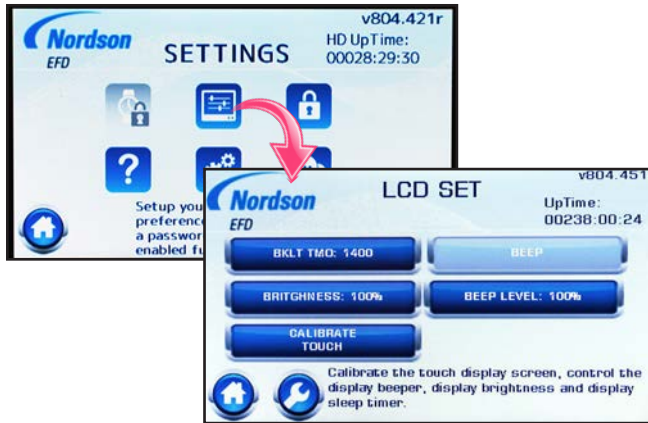

Icon	Description	
 LCD SETTINGS	Provides access to the LCD settings and adjustments.	
	Setting	Description
	BKLT TMO (backlight timeout)	Sets how long the touchscreen remains on with no user interaction before entering a sleep mode. Touch any part of the screen to restore the display.
	BRIGHTNESS	Sets the touchscreen brightness (25–100 %).
	CALIBRATE TOUCH	Opens the LCD calibration screen.
	BEEP	Enables or disables the button-press beep sound.
BEEP LEVEL	Sets the button-press beep volume (5–100 %).	

FUNCTION LOCKOUT Screen

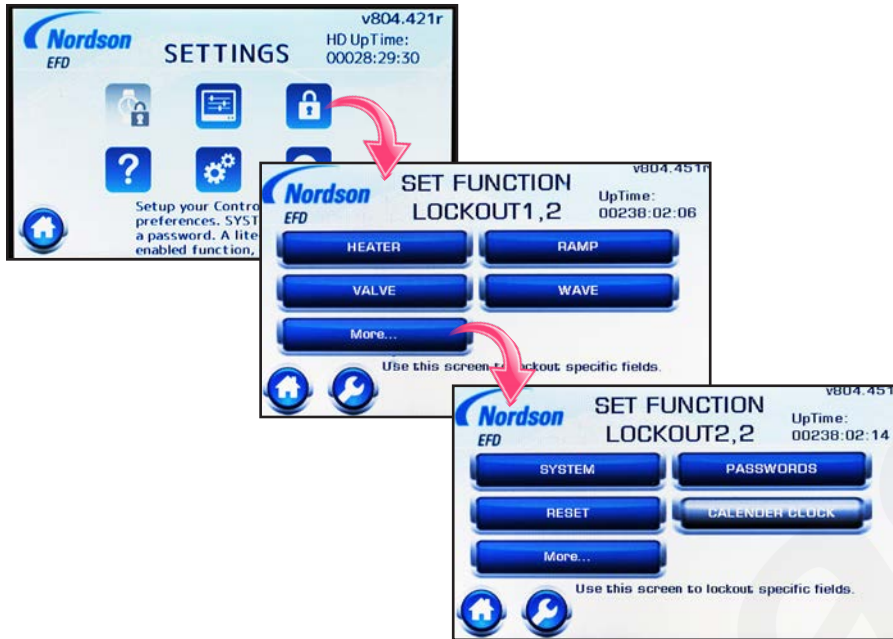

Icon	Description																		
 LOCKOUTS (LOCKOUT password required for access)	<p>Opens the FUNCTION LOCKOUT screen, which provides access to the following settings that can be locked against user modification. Locked settings are password-protected — to view or change a locked setting, you must enter the LOCKOUT password.</p> <p>NOTE: Changing the LOCKOUT password AND also enabling the SYSTEM lockout removes the ability to perform an emergency password reset. Contact Nordson EFD Technical Services if you forget your custom LOCKOUT password and you have enabled the SYSTEM lockout.</p> <table border="1"> <thead> <tr> <th>Lockout</th> <th>Description</th> </tr> </thead> <tbody> <tr> <td>HEATER</td> <td>When enabled, requires users to enter the LOCKOUT password to change the following HEATERS settings: MODE, SETTING.</td> </tr> <tr> <td>VALVE</td> <td>When enabled, requires users to enter the LOCKOUT password to change the following VALVE settings: MODE, PULSE, CYCLE, COUNT, On / Off.</td> </tr> <tr> <td>RAMP</td> <td>When enabled, requires users to enter the LOCKOUT password to change the following RAMP settings: STROKE, CLOSE, OPEN, CLOSE VOLTS.</td> </tr> <tr> <td>WAVE</td> <td>When enabled, requires users to enter the LOCKOUT password to select any field on the WAVE PROFILE screen.</td> </tr> <tr> <td>SYSTEM</td> <td>When enabled, requires users to enter the SYSTEM password to access the SYSTEM screen.</td> </tr> <tr> <td>RESET</td> <td>When enabled, requires users to enter the RESET password to reset the system.</td> </tr> <tr> <td>PASSWORDS</td> <td>When enabled, requires users to enter the LOCKOUT password to access the SET PASSWORDS screen.</td> </tr> <tr> <td>CALENDAR CLOCK</td> <td>CALENDAR CLOCK lockout is currently disabled. It will be available in a future release.</td> </tr> </tbody> </table>	Lockout	Description	HEATER	When enabled, requires users to enter the LOCKOUT password to change the following HEATERS settings: MODE, SETTING.	VALVE	When enabled, requires users to enter the LOCKOUT password to change the following VALVE settings: MODE, PULSE, CYCLE, COUNT, On / Off.	RAMP	When enabled, requires users to enter the LOCKOUT password to change the following RAMP settings: STROKE, CLOSE, OPEN, CLOSE VOLTS.	WAVE	When enabled, requires users to enter the LOCKOUT password to select any field on the WAVE PROFILE screen.	SYSTEM	When enabled, requires users to enter the SYSTEM password to access the SYSTEM screen.	RESET	When enabled, requires users to enter the RESET password to reset the system.	PASSWORDS	When enabled, requires users to enter the LOCKOUT password to access the SET PASSWORDS screen.	CALENDAR CLOCK	CALENDAR CLOCK lockout is currently disabled. It will be available in a future release.
Lockout	Description																		
HEATER	When enabled, requires users to enter the LOCKOUT password to change the following HEATERS settings: MODE, SETTING.																		
VALVE	When enabled, requires users to enter the LOCKOUT password to change the following VALVE settings: MODE, PULSE, CYCLE, COUNT, On / Off.																		
RAMP	When enabled, requires users to enter the LOCKOUT password to change the following RAMP settings: STROKE, CLOSE, OPEN, CLOSE VOLTS.																		
WAVE	When enabled, requires users to enter the LOCKOUT password to select any field on the WAVE PROFILE screen.																		
SYSTEM	When enabled, requires users to enter the SYSTEM password to access the SYSTEM screen.																		
RESET	When enabled, requires users to enter the RESET password to reset the system.																		
PASSWORDS	When enabled, requires users to enter the LOCKOUT password to access the SET PASSWORDS screen.																		
CALENDAR CLOCK	CALENDAR CLOCK lockout is currently disabled. It will be available in a future release.																		

SYSTEM Screens

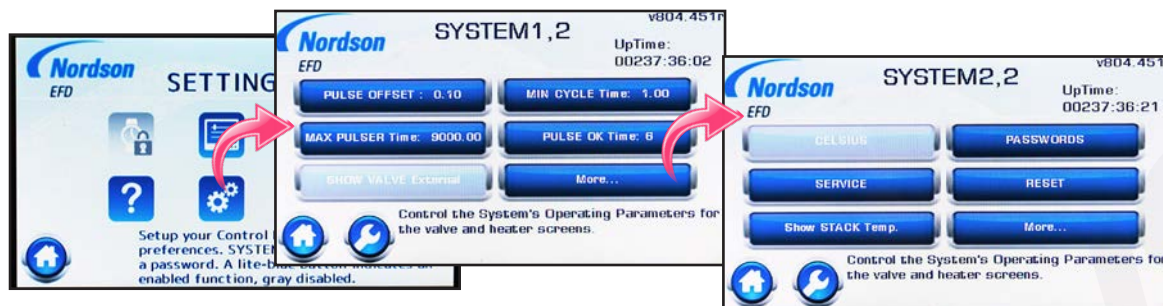

Icon	Description	
 SYSTEM (SYSTEM password required for access)	Opens the SYSTEM screen, which provides access to the system-level settings.	
	Setting	Description
	PULSE OFFSET	Sets a minimum time (in ms) difference allowed between the VALVE screen CYCLE and PULSE settings. For example, if PULSE OFFSET is set to 3 and a user enters 1.00 (ms) for CYCLE, then the setting entered for PULSE must be 4.00 ms or greater.
	MAX PULSER Time	Sets the maximum time (in ms) that the CYCLE icon can be held active in the Continuous mode or when purging.
	SHOW VALVE External	Adds EXTERNAL to the MODE selections available on the VALVE screen. Refer to MODE under "VALVE Screen" on page 19 for additional information on the external mode.
	MIN CYCLE Time	Sets a minimum time (in ms) that can be entered for CYCLE on the VALVE screen. The controller automatically modifies an entered CYCLE setting if it exceeds the safe operating range of the connected valve. For example, for an SD valve, the controller limits the CYCLE time to a minimum of 4 ms (250Hz). Default: 30 (ms)
	PULSE OK Time	Sets how long the PULSE OK output signal (pin 14 on the 15-pin I/O connector) stays on AFTER the current dispense parameters are executed. Default: 6 (ms) Range: 1–100 (ms)
	CELSIUS or FAHRENHEIT	Sets how temperature units are displayed (Celsius or Fahrenheit).
	SERVICE	Nordson EFD use only.
	Show STACK Temp.	When SHOW STACK TEMP is toggled on, the controller displays the actual temperature of the piezo actuator stack on the VALVE screen. When SHOW STACK TEMP is toggled off, the stack temperature is not displayed. NOTE: This setting becomes useful when the valve is operating at the higher end of its operating range. Stack temperature is a crucial variable that can cause the controller to generate an alarm as it tries to protect the valve. For example, if an SD valve is running at a high frequency, the stack temperature increases. Once the stack temperature reaches 55° C (131° F), the controller generates an alarm because the valve temperature is getting too hot.
PASSWORDS	Opens the SET CONTROL PASSWORD screen, which provides access to the password setup options. Refer to "Managing Password Protection" on page 36 for additional information.	
RESET	Forces a reset of the LCD and re-initiates communication with the controller. All settings return their factory default values. Performing a reset causes an LCD fault alarm.	

Installation

Use this section in tandem with the quick start guide and any other system component operating manuals to install all components of the system.

Unpack the System Components



- 1 PICO *Touch* controller
- 2 Power cord, American plug, *Touch* controller, 2 m (6.6 ft)
- 3 Cable, USB, A male to B male, 2 m (6.6 ft)
- 4 Backshell, I/O, 15 position, D-sub
- 5 Connector, I/O, 15 position, D-sub
- 6 Power supply, *Touch* controller, 1 m (3.3 ft)
- 7 PICO *Pulse* valve (ordered separately)
- 8 Extension cable (optional)

(Not shown)
 Welcome letter
 Quick start guide

Install the Valve and Controller

The callouts in the system installation images correspond to the steps in this procedure.

1. Install any components other than the *Pulse* valve and controller that will comprise the complete dispensing system. For example, if you are using a fluid reservoir, position and install all the fluid reservoir components. For all ancillary components, refer to the quick start guide and / or operating manual provided with those components for installation, setup, and operating instructions.

⚠ CAUTION

Ensure that air can flow around the controller. Blocked air flow can cause overheating.

2. Install or position the *Touch* controller. The controller can be integrated into existing machinery or used as a tabletop device:
 - To integrate the controller into existing machinery, remove the feet (if needed) and use the following specifications to install it as a standard rack mount:
 - Height: 3U
 - Width: 28 Hp
 - Depth: for 160 mm (6.3")
 - To use the controller as a tabletop device, lower the hinged legs.
 - Ensure there is adequate air flow around the controller.
3. Connect power to the controller as follows:
 - a. Connect the power and extension cables to the back of the controller and to your local power source observing the following guidelines:
 - Use only the supplied power cable and power supply.
 - Ensure that the power source is located near the equipment and is easily accessible.
 - Use only on a circuit with a fuse or circuit breaker that is 20 Amp or less.
 - b. Connect a 16 AWG (1.3 mm) ground wire to the chassis grounding screw on the rear of the chassis using a toothed grounding lug. The wire must have green insulation with a yellow stripe or must be non-insulated (bare).
 - c. Attach the opposite end of the ground wire to a permanent earth ground using toothed washers or a toothed lug.



Install the Valve and the Controller (continued)

⚠ CAUTION

Always switch OFF the *Touch* controller before connecting or disconnecting the valve. Failure to do so can damage the controller and the valve.

4. Assemble and mount the *Pulse* valve as follows:
 - a. Open the hinged seat of the piezo actuator by pushing the latch pin back towards the valve.
 - b. Insert the fluid body assembly and close the hinged seat, ensuring it is fully engaged.
 - c. (Optional) Secure the valve to the mounting bracket. There are multiple mounting holes to allow for adjustment.
 - d. Install the valve on the dispensing equipment.

NOTE: Valve mounting kits are available. Refer to the valve operating manual.

- e. Connect the valve power and communication cables to the 3-pin and 5-pin connectors on the back of the *Touch* controller. Refer to "Replacement Parts" on page 42 for available extension cables.
- f. To divert static charges from the valve, connect it to the machine system ground. Vacant fastening threads may be used for this.
- g. Add the fluid supply, but do not pressurize the fluid supply at this point.

NOTE: For low viscosity fluids used in a syringe barrel application, fill the barrel **after** installing it on the fluid-inlet fitting. High viscosity materials can be loaded into the barrel before installing it on the inlet fitting.

5. Connect inputs / outputs (I/O) to I/O 1 and I/O 2 as needed for your operation. Refer to "Input / Output Port Pin Descriptions" on page 46 for detailed I/O information. A 15-position D-sub and backshell are provided. A cable for the 25-pin D-sub connection is customer-supplied.

NOTE: Nordson EFD recommends using the analog temperature output (DSUB pin 11) to provide operators with appropriate identification and protection against contact when the valve temperature exceeds +45° C (113° F).



Install the Valve and the Controller (continued)

⚠ CAUTION

Do not dry cycle the *Pulse* valve! The ceramic nozzle seat and ball can be damaged if the valve is operated without fluid, causing leakage and a poor seal. Precise dispensing can no longer be guaranteed if this occurs.

6. Start up and test the system as follows:

- a. Switch the *Touch* controller power ON and complete the touchscreen calibration as prompted (required only at initial startup).

- b. (Heated systems only):

- Press the HEATERS icon (🔥) and then enter a temperature SETTING that is just above the ambient temperature (or as appropriate for the fluid).
- Press ON to switch the HEATERS mode to On.
- Wait for the system to reach temperature setpoint.

NOTE: The HEATERS screen shows the actual temperature of the valve.

- c. **IMPORTANT:** Press the VALVE icon (⚙️) and then press POWER to switch the valve ON.

- d. Introduce fluid to the system.

- e. Set the reservoir pressure lower for thin fluids and higher for thick fluids [approximately 0.4–1.0 bar (5–15 psi), depending on the fluid]. For tanks, use the in-line air shut-off valve to pressurize or de-pressurize the fluid supply. For syringe barrels, connect or disconnect the adapter assembly from the reservoir pressure regulator and gauge.

- f. Press the PURGE icon (🔄) and allow fluid to purge from the system until the fluid flow is steady.

- g. Press MODE and enter the following recommended settings to test an actual deposit:

- MODE = Timed
- PULSE = 0.5 (ms)
- CYCLE = 5 (ms)
- COUNT = 10

- h. Press the CYCLE icon (🔄).

The system dispenses 10 deposits and displays the frequency (FREQ) indication on the VALVE screen.

- i. Make parameter adjustments until the desired deposit result is achieved. Use caution not to exceed maximum frequency ranges.

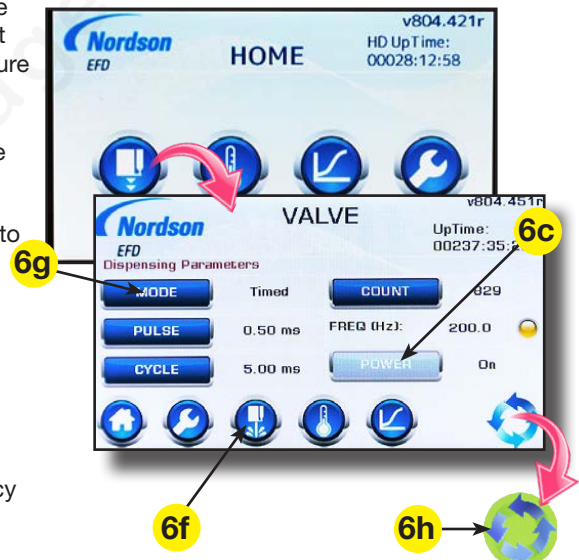

Setup and Programming Procedures

Use these procedures as needed to finalize setup, fine-tune the performance of the system, or view / change settings.

NOTE: These procedures show data being entered manually at the *Touch* controller. To operate the controller remotely, refer to "Appendix A, Remotely Operating the Controller" on page 53.

Connecting a Valve Initiate Signal

Follow this procedure to connect a clean, bounce-free input signal to initiate valve dispense cycles.

- IMPORTANT:** Connect a clean, bounce-free valve initiate signal to the following pins of the I/O port on the back of the controller:

- Pin 3 — USET Metering Start High (Valve Initiate)
- Pin 4 — USET Metering Start Low (GND)

Refer to "Input / Output Port Pin Descriptions" on page 46 for detailed I/O information.

- Change the operating mode to Timed.

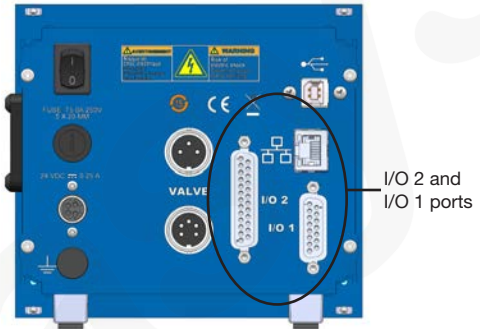

Changing the System (VALVE) Operating Mode

Follow this procedure to change the operating mode. For more information on the modes, refer to "VALVE Screen" on page 19.

- Press the VALVE icon (🔧).
- Press MODE until the touchscreen shows the desired operating mode.

Timed: The valve cycles according to the settings for PULSE (valve open time), CYCLE (time between deposits), and COUNT (number of deposits) for each valve initiate signal. When you press the CYCLE icon, the system dispenses for one cycle.

Continuous: The valve cycles according to the settings for PULSE (valve open time) and CYCLE (time between deposits) for as long as the valve initiate signal is active, ignoring any setting for COUNT (number of deposits). When you press the CYCLE icon, the system opens the valve for 10 seconds or until you press the CYCLE icon again, ignoring COUNT.

External: The controller operates as a slave to an input signal and ignores all programmed settings. Refer to "VALVE Screen" on page 19 for cautions and important information about this mode.

- Press HOME to save the setting and return to the HOME screen.



CYCLE icon

ABOUT ?	CALENDAR CLOCK SET 🕒	OK (check) ✓	LANGUAGE 🗣️	RAMP ↙️
Backspace ⬅️	Cancel ❌	HEATERS 🔥	LOCKOUTS 🔒	SETTINGS ⚙️
LCD SETTINGS 📄	Decimal Point 🗂️	HOME 🏠	PASSWORDS 🔑	SYSTEM ⚙️
CYCLE 🔄	Decrement -	Increment +	PURGE 🚰	VALVE 🔧

Setup and Programming Procedures (continued)

Adjusting the Valve Operating Parameters (PULSE, CYCLE, or COUNT)

Follow this procedure to adjust how the valve operates, including valve open time (PULSE), time between deposits (CYCLE), and number of deposits per cycle (COUNT). For more information on these parameters, refer to "VALVE Screen" on page 19.

1. Press the VALVE icon (🔧).
2. Press PULSE, CYCLE, or COUNT. A numeric keypad appears for data entry.
3. Enter the desired setting for PULSE, CYCLE, or COUNT.
 - **PULSE:** How long the valve stays opens (in ms).
 - **CYCLE:** Amount of time between deposits (in ms).
 - **COUNT:** Number of deposits per cycle.
4. Press OK (check) > HOME to save the setting and return to the HOME screen.



Switching Valve Power On or Off

Follow this procedure to set whether a valve initiate signal is processed. Valve initiate signals are processed only when valve Power is ON.

NOTE: By default, valve POWER is ON when the controller is switched ON (or anytime the controller is rebooted). To change the valve POWER setting default, refer to "Appendix A, Remotely Operating the Controller" on page 53.

1. Press the VALVE icon (🔧).
2. Press POWER until the touchscreen shows the desired valve power status.
 - **On:** Valve closed; valve initiate signals processed.
 - **Off:** Valve open; valve initiate signals NOT processed.
3. Press HOME to save the setting and return to the HOME screen.



ABOUT ?	CALENDAR CLOCK SET 🕒	OK (check) ✓	LANGUAGE 🗣️	RAMP ↙️
Backspace ↩️	Cancel ❌	HEATERS 🔥	LOCKOUTS 🔒	SETTINGS ⚙️
LCD SETTINGS 📄	Decimal Point 🗂️	HOME 🏠	PASSWORDS 🔑	SYSTEM ⚙️
CYCLE 🔄	Decrement -	Increment +	PURGE 🚰	VALVE 🔧

Setup and Programming Procedures (continued)

Switching the Heater Control (MODE) to On, Off, or Remote

Follow this procedure to switch the heater control on or off or to change the heater mode to remote operation.

1. Press the HEATERS icon (🔥).
2. Press the button for the desired heater mode.
 - **Off:** Heater control switches OFF.
 - **On:** Heater control switches ON.
 - **Remote:** Heater control follows a remote input signal (refer to "Input / Output Port Pin Descriptions" on page 46 to connect inputs / outputs).
3. Press HOME to save the setting and return to the HOME screen.



Viewing or Changing the Valve Heater Temperature / Temperature Setpoint

Follow this procedure to view or change the valve heater setpoint temperature or to view the actual temperature of the valve heater.

1. Press the HEATERS icon (🔥).
2. Press SETTING and enter the desired temperature setpoint on the numeric keypad.

NOTES:

- The actual temperature of the heater is displayed on the touchscreen next to ACTUAL.
 - To change how temperature units are displayed, refer to "Viewing or Changing System Settings" on page 35.
3. Press OK (check) > HOME to save the setting and return to the HOME screen.

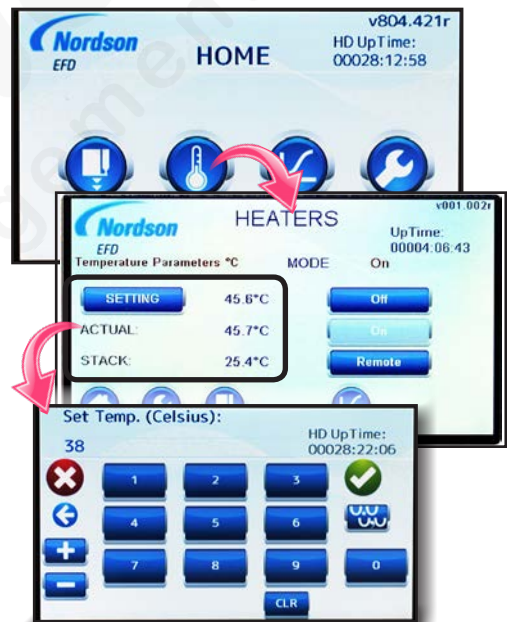

ABOUT ?	CALENDAR CLOCK SET 🕒	OK (check) ✓	LANGUAGE 🗣️	RAMP ⏸️
Backspace ⬅️	Cancel ❌	HEATERS 🔥	LOCKOUTS 🔒	SETTINGS ⚙️
LCD SETTINGS 📄	Decimal Point 🗂️	HOME 🏠	PASSWORDS 🔑	SYSTEM ⚙️
CYCLE 🔄	Decrement -	Increment +	PURGE 🚰	VALVE 🔧

Setup and Programming Procedures (continued)

Connecting a Controller Status Monitoring Signal

The *Pulse* valve is normally open and power must be applied to close it. In the case of damage to the piezo actuator or the *Touch* controller, the valve may transition from a CLOSED to an OPEN condition, which can cause fluid release. Nordson EFD recommends continually monitoring the status signal of the *Touch* controller and immediately and automatically de-pressurizing the system if the signal indicates an error. Follow this procedure to connect a controller status monitoring signal.

Connect wiring from the monitoring device to the following pins of the I/O port on the back of the controller:

- Pin 7 — Power signal
- Pin 13 — Error Out signal

Refer to "Input / Output Port Pin Descriptions" on page 46 for detailed I/O information.

Adjusting the Wave Profile

The WAVE PROFILE screen includes valve close and valve open profile selections for optimizing or fine-tuning your dispensing results. The Close profiles affect how fast the valve closes. The Open profiles affect how fast the valve opens. You can also choose RAMP, which allows the system to create Open and Close profiles based on the values entered on the RAMP screen.

NOTE: Buttons are available for custom wave profiles. Contact your Nordson EFD representative for information on creating custom wave profiles and for using the pre-programmed wave profile selections.

1. Press the RAMP icon ().
2. Select the desired wave profile for Close (how fast the valve closes) and / or Open (how fast the valve opens), or

Press RAMP to open the RAMP screen. On the RAMP screen, enter the values you want the system to use to create Close and Open profiles.

- **CLOSE VOLTS:** The voltage applied to close the valve. The higher the voltage, the greater the sealing force applied.
- **STROKE:** The voltage applied for each initiate cycle. For example, a CLOSE VOLTS setting of 120V and a STROKE setting of 50% means that when the valve actuates, the voltage changes from 120V to 60V and then back to 120V, as shown by the wave profile PREVIEW.
- **OPEN:** How fast the valve opens.
- **CLOSE:** How fast the valve closes.
- **PREVIEW:** Opens the RAMP GRAPH screen, which displays a graph of the CLOSE: > RAMP and OPEN: > RAMP wave profile (this screen does not provide a graph for any custom profiles).

NOTE: Minimum limits are valve-specific and will be updated by the controller if they are exceeded.

3. Press HOME to save the setting and return to the HOME screen.

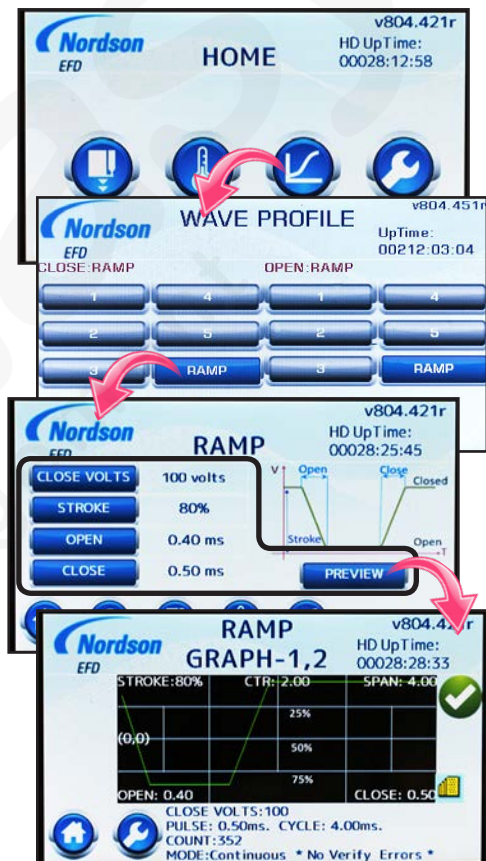

Setup and Programming Procedures (continued)

Viewing or Changing System Settings

Follow this procedure as needed to view or change the SYSTEM settings explained under "SYSTEM Screens" on page 26.

1. Press the SETTINGS icon (🔧).
2. Press the SYSTEM icon (🔧) and enter the SYSTEM password.
3. Press MORE... to toggle between the SYSTEM1,2 and SYSTEM2,2 screens.
4. Refer to the SYSTEM section of the "SYSTEM Screens" on page 26 for detailed information the following SYSTEM screen selections:
 - PULSE OFFSET
 - MAX PULSE Time
 - SHOW VALVE External
 - MIN CYCLE Time
 - PULSE OK Time
 - CELSIUS / FAHRENHEIT (how temperature units display)
 - SERVICE
 - Show STACK Temp.

NOTE: For PASSWORDS, refer to "Managing Password Protection" on page 36.

NOTE: For RESET, refer to "Restoring the System to the Factory Default Settings" on this page.

5. Press HOME to save the setting and return to the HOME screen.

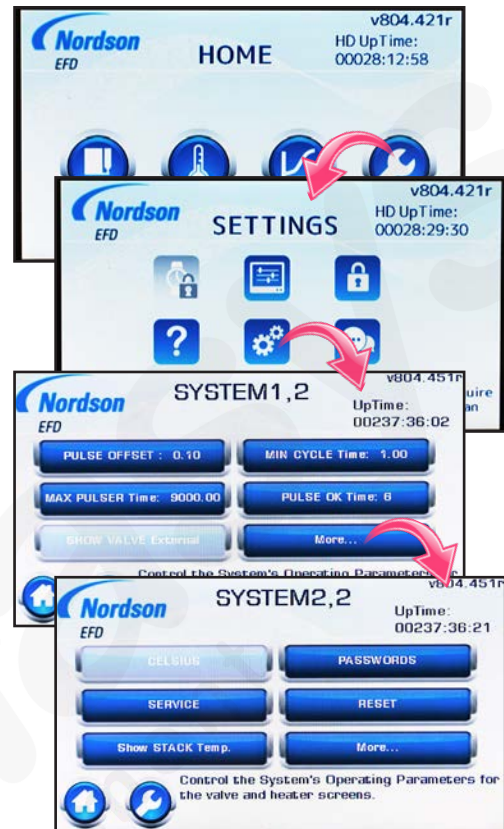

Restoring the System to the Factory Default Settings

Follow this procedure to restore all system settings to their factory-default values.

1. Press the SETTINGS icon (🔧).
2. Press the SYSTEM icon (🔧).
3. Press MORE... > RESET > and enter the RESET password.
4. Press OK (check) to reset the system. The system prompts for verification.

ABOUT ?	CALENDAR CLOCK SET 🕒	OK (check) ✓	LANGUAGE 🗨️	RAMP ↻
Backspace ⬅️	Cancel ❌	HEATERS 🔥	LOCKOUTS 🔒	SETTINGS 🔧
LCD SETTINGS 📄	Decimal Point 📏	HOME 🏠	PASSWORDS 🔑	SYSTEM 🔧
CYCLE 🔄	Decrement -	Increment +	PURGE 🚰	VALVE 🚰

Setup and Programming Procedures (continued)

Managing Password Protection

The controller requires one of three password types to access some screens.

Password Type	Function	Default Password
SYSTEM	Protects the SYSTEM and SET PASSWORDS screens.	EFD_STM
LOCKOUT	Protects the SET FUNCTION LOCKOUT screens.	EFD_LOK
RESET	Protects the factory-reset function.	EFD_RST (non-editable)

Changing a SYSTEM or LOCKOUT Password

NOTE: To password-protect (lock out) additional menu items, refer to "Managing Lockouts" on page 37.

1. Press the SETTINGS icon (⚙️).
2. Press the SYSTEM icon (⚙️) and enter the SYSTEM password.
3. Press MORE... > PASSWORDS > and enter the SYSTEM password.
4. Press SYSTEM or LOCKOUT and then enter the new password. Passwords are limited to eight (8) characters.
5. Press OK (check) > HOME to save the setting and return to the HOME screen.

Resetting the SYSTEM and LOCKOUT Passwords

If you forget a SYSTEM or LOCKOUT password, follow this procedure to reset the passwords to their defaults.

NOTE: Changing the LOCKOUT password AND also enabling the SYSTEM lockout removes the ability to perform this password reset. Contact Nordson EFD Technical Services if you forget your custom LOCKOUT password and you have enabled the SYSTEM lockout.

1. Press the SETTINGS icon (⚙️).
2. Press the SYSTEM icon (⚙️).
3. When prompted for the SYSTEM password, enter PICO_TOUCH.
The SYSTEM and RESET passwords are restored to their defaults and the controller opens the SET PASSWORDS screen.
4. Enter new passwords or press HOME to accept the factory defaults.

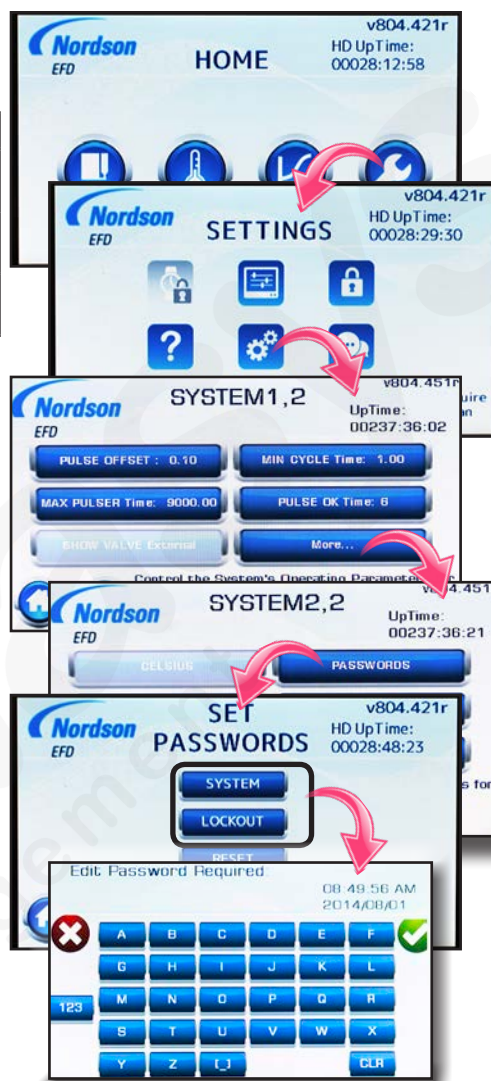

ABOUT ?	CALENDAR CLOCK SET 🕒	OK (check) ✓	LANGUAGE 🗨️	RAMP ↙️
Backspace ↩️	Cancel ❌	HEATERS 🔥	LOCKOUTS 🔒	SETTINGS ⚙️
LCD SETTINGS 📄	Decimal Point 🗂️	HOME 🏠	PASSWORDS 🔑	SYSTEM ⚙️
CYCLE 🔄	Decrement -	Increment +	PURGE 🚰	VALVE 🚰

Setup and Programming Procedures (continued)

Managing Lockouts

Lockouts block access to specific screens or menu items to prevent unintended changes, thus providing an additional layer of protection. When a screen or menu item is locked out, it cannot be accessed.

1. Press the SETTINGS icon (🔧).
2. Press the LOCKOUTS icon (🔒) and then enter the LOCKOUT password.
3. The SET FUNCTION LOCKOUT 1, 2 screen appears. Press MORE to see the SET FUNCTION LOCKOUT 2, 2 SCREEN.

The following table shows the control functions that can be locked out for each selection.

Button	Lockout Options
HEATER	MODE or SETTING buttons
VALVE	MODE, PULSE, CYCLE, COUNT, or On / Off buttons
RAMP	STROKE, CLOSE, OPEN, or CLOSE VOLTS buttons
WAVE	Close 1, 2, 3, 4, 5, or RAMP buttons Open 1, 2, 3, 4, 5, or RAMP buttons
SYSTEM	SYSTEM screen (locks out entire screen)
RESET	RESET button (locks out the factory reset function)
PASSWORDS	SET PASSWORDS screen (locks out entire screen)
CALENDAR CLOCK	Not available.

4. Make your desired selections. Press HOME to save the setting and return to the HOME screen.

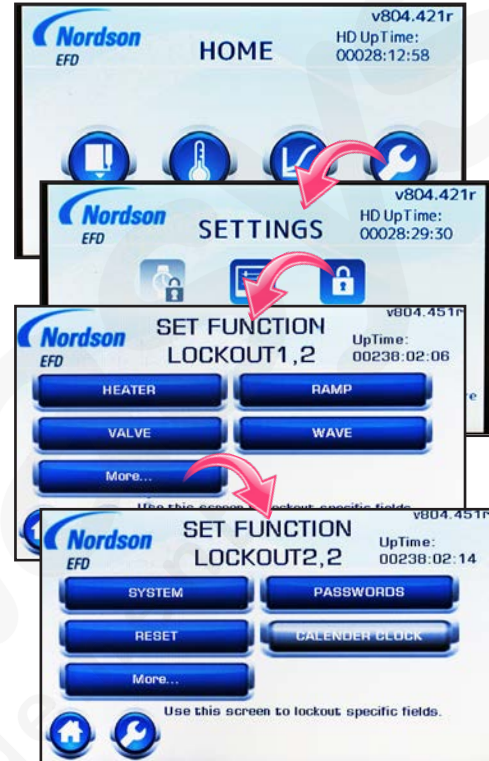

Example of a lockout screen (LOCKOUT RAMP FIELDS shown)

ABOUT ?	CALENDAR CLOCK SET 🕒	OK (check) ✓	LANGUAGE 🗣️	RAMP 📈
Backspace ⬅️	Cancel ❌	HEATERS 🔥	LOCKOUTS 🔒	SETTINGS ⚙️
LCD SETTINGS 📄	Decimal Point 📏	HOME 🏠	PASSWORDS 🔑	SYSTEM ⚙️
CYCLE 🔄	Decrement -	Increment +	PURGE 🚰	VALVE 📊

Setup and Programming Procedures (continued)

Adjusting the LCD and Beep Settings

Follow this procedure to make LCD and beep-sound adjustments.

1. Press the SETTINGS icon (🔧).
2. Press the LCD SETTINGS icon (📄).
3. Enter the desired setting for BKLT TMO, BEEP, BRIGHTNESS, and BEEP LEVEL.
 - **BKLT TMO:** How long the touchscreen remains on with no user interaction before entering a sleep mode (touch any part of the screen to restore the display).
 - **BEEP:** Switches the button-press beep sound on or off.
 - **BRIGHTNESS:** Sets the touchscreen brightness (25–100%).
 - **BEEP LEVEL:** Sets the button-press beep volume (5–100%).
4. Press OK (check) > HOME to save the setting and return to the HOME screen.

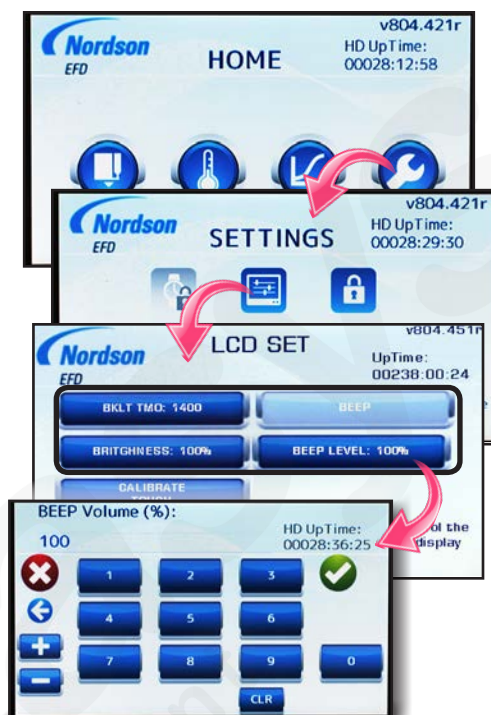

Calibrating the LCD

1. Press the SETTINGS icon (🔧).
2. Press the LCD SETTINGS icon (📄).
3. Press CALIBRATE TOUCH.
4. Follow the on-screen directions to calibrate the touchscreen.
5. Press OK (check) > HOME to save the setting and return to the HOME screen.

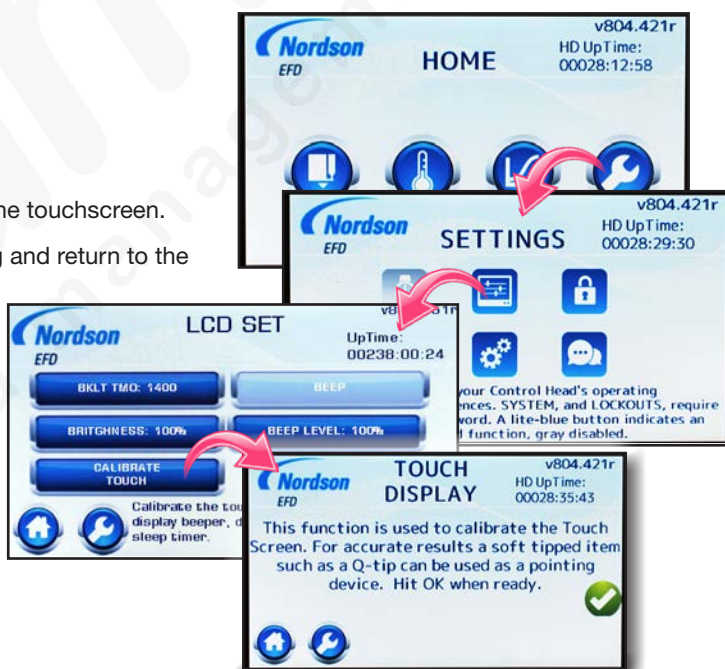

ABOUT ?	CALENDAR CLOCK SET 🕒	OK (check) ✓	LANGUAGE 🗣️	RAMP 📏
Backspace ⬅️	Cancel ❌	HEATERS 🔥	LOCKOUTS 🔒	SETTINGS ⚙️
LCD SETTINGS 📄	Decimal Point 🗂️	HOME 🏠	PASSWORDS 🔑	SYSTEM ⚙️
CYCLE 🔄	Decrement -	Increment +	PURGE 🚰	VALVE 🚰

Setup and Programming Procedures (continued)

Setting the Language

1. Press the SETTINGS icon (🔧).
2. Press the LANGUAGE icon (🗨️).
3. Press MORE... to toggle through the SET LANGUAGE screens.
4. Press the button for the correct language.
5. Press HOME to save the setting and return to the HOME screen.



Viewing the Controller and Valve Information

Firmware resides in three locations in a PICO Touch system: on the main circuit board inside the Touch controller, on the LCD circuit board, and on a small circuit board inside the Pulse valve.

1. Press the SETTINGS icon (🔧).
2. Press the ABOUT icon (❓).
3. Press MORE... to see the ADDITIONAL INFORMATION screen.

The ABOUT and ADDITIONAL INFORMATION screens provide the current system information. Refer to "SETTINGS Screen" on page 23 for additional details on these screens.

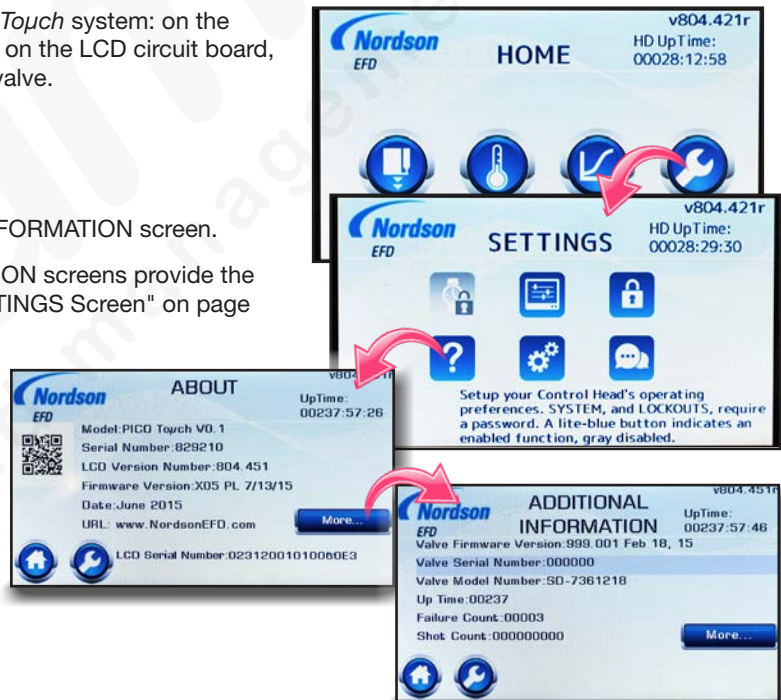

ABOUT	🔍	CALENDAR CLOCK SET	🕒	OK (check)	✅	LANGUAGE	🗨️	RAMP	📈
Backspace	⬅️	Cancel	❌	HEATERS	🔥	LOCKOUTS	🔒	SETTINGS	🔧
LCD SETTINGS	📄	Decimal Point	🔢	HOME	🏠	PASSWORDS	🔑	SYSTEM	⚙️
CYCLE	🔄	Decrement	➖	Increment	➕	PURGE	🚰	VALVE	🔧

Operation

Follow these recommended procedures for daily / routine startup and shutdown to obtain the best performance from your system.

⚠ CAUTION

The *Pulse* valve is normally open and power must be applied to close it. In the case of damage to the piezo actuator or the *Touch* controller, the valve may transition from a CLOSED to an OPEN condition, which can cause fluid release. Nordson EFD recommends continually monitoring the status signal of the *Touch* controller and immediately and automatically de-pressurizing the system if the signal indicates an error.

Routine Startup

1. If the process requires a heated valve, press the HEATERS icon and then press ON to switch the HEATERS mode to On.

NOTE: Upon reboot, the controller remembers the last selected HEATERS mode.

2. Press the VALVE icon and then MODE until the touchscreen shows the desired operating mode.
3. Start your process.

Purging the System

Press the VALVE > PURGE icons as needed to clear debris or after changing the fluid body assembly. Refer to the valve operating manual for more detailed information on purging and system cleaning.



Switching on heater control

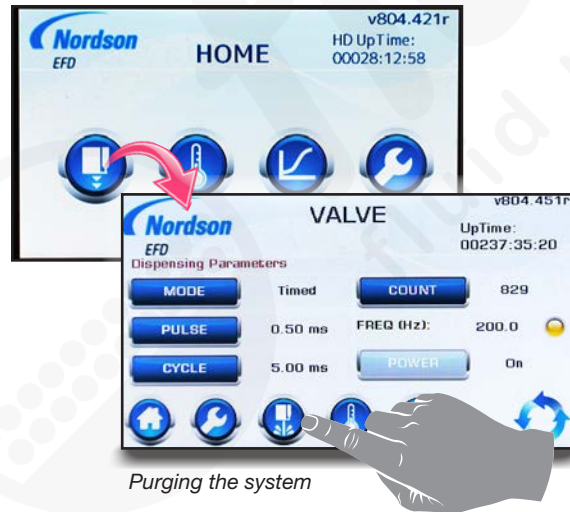

Purging the system



Placing the system in the Timed mode

Operation (continued)

Clearing Alarms

When an alarm occurs, the screen title bar blinks red and an alarm window appears. The window indicates the alarm type. System alarms include:

Alarm	Cause
No Valve Detected	System cannot detect a valid valve connected to the controller.
Stack Over Temperature	System operating beyond its acceptable range; typically caused by high frequency operation.
Piezo Driver FAULT	Error occurred with the piezo driver circuitry. NOTE: Press MORE DETAILS to obtain specific information about the cause of this alarm.
Pulse Time Adjusted	Parameters entered for RAMP do not coincide with PULSE and CYCLE times; OR, if running in External mode, dispense timing parameters are violated.
Driver Shut Off	Piezo driver unexpectedly shut off and the system recovered; typically caused by improper use or installation.
Valve Communications Error	Controller experiencing valve communication issues; typically caused by a faulty physical connection.
LCD Fault	Problem occurred with LCD display.
Heater Fault	Heater failed or shorted RTD in the valve.



Clearing an alarm

When an alarm occurs:

1. Clear the alarm. Alarms can be cleared in two ways:
 - Locally at the controller by pressing OK (check).
 - Remotely through pin 6 (Error Reset) of the I/O 1 (input / output) connector. Refer to "Input / Output Port Pin Descriptions" on page 46 to connect inputs / outputs.
2. If needed, correct the problem that caused the alarm. Refer to "Troubleshooting" on page 44 for additional troubleshooting information.

Routine Shutdown

1. Stop the process.
2. De-pressurize the system.

WARNING

Risk of burns. Wear heat-protective gloves when working with a heated valve.

3. If the valve is heated, switch OFF heater control.
4. Refer to the valve manual to perform any of the following procedures as appropriate for the fluid:
 - Removing the fluid body assembly.
 - Purging the valve with the process fluid.
 - Purging the valve with cleaning fluid.
 - Cleaning the valve fluid paths.

Part Number

Part #	Description
7361217	PICO Touch controller



Replacement Parts

NOTE: Refer to the PICO Pulse valve operating manual for replacement valve parts.

Controller Components

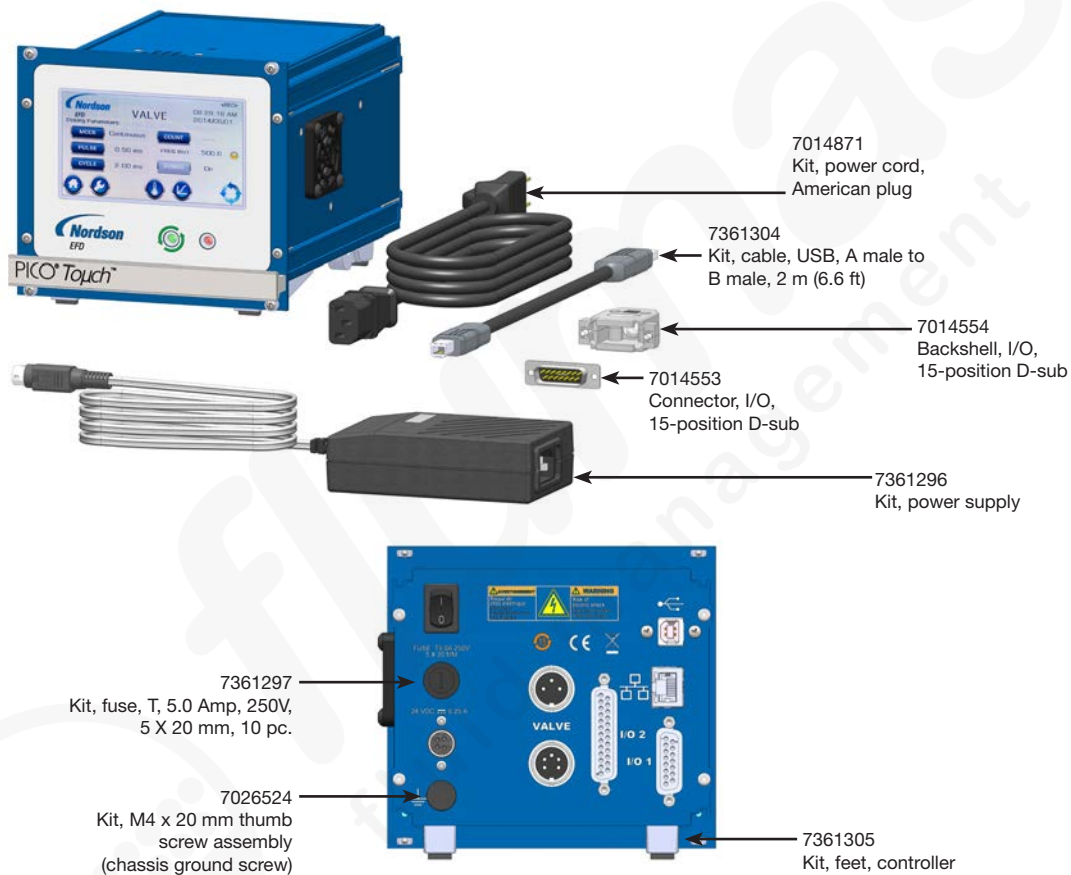

Replacement Parts (continued)

Valve Extension Cables

Part Number	Description
7362085	0.6 m (2.0 ft) valve extension cable set
7361298	2 m (6.6 ft) valve extension cable set
7361299	6 m (19.7 ft) valve extension cable set
7361300	9 m (29.5 ft) valve extension cable set



Filter



Troubleshooting

Problem	Possible Cause	Corrective Action
Fluid leaks	Valve not powered ON	Verify that the valve POWER is ON.
	Insufficient closing voltage	Increase the closing voltage of the valve.
	Improper profile selected	If RAMP is not selected for the open and close WAVE PROFILE settings, verify that the selected profile is correctly programmed.
	Worn or damaged valve	Refer to the troubleshooting section of the valve operating manual.
	Damaged driver	Contact Nordson EFD.
Valve will not power ON	Loose or damaged cable / connection	Verify that both valve input cables are connected. Check the integrity of all cables and connections.
	Alarm condition present	Correct and clear any pending alarms.
	System Alarm: Piezo Driver FAULT	Check for a Piezo Driver FAULT alarm. If this continues to occur, contact Nordson EFD.
	Improper profile selected	If RAMP is not selected for the open and close WAVE PROFILE settings, verify that the selected profile is correctly programmed. Switch off the controller and wait 5 seconds for the valve to fully discharge. Disconnect and reconnect all cables to the controller, then switch on the controller. If a system restart does not correct the problem, contact Nordson EFD.
Controller not responding to an initiate signal	Alarm condition present	When an alarm condition is present, the controller will not initiate. Correct and clear any pending alarms.
	Problem with initiate signal integrity	Verify that the signal being user on the USET (Initiate) circuit is a clean, bounce-free signal (5-24VDC).
	Problem with wiring integrity	Ensure that the wiring is correctly stripped and that the conductors are making contact on the 15 pin connector
	Valve not powered ON	Verify that the valve POWER is ON.
LCD not responding to touches	LCD requires calibration	Refer to "Calibrating the LCD" on page 38 to recalibrate the LCD.
	System Alarm: LCD Fault	Switch off the controller and wait 5 seconds for the valve to fully discharge, then switch on the controller.
System Alarm: No Valve Detected	Loose or disconnected valve cable	Verify that both valve input cables are connected. Check the integrity of cables and connections.
System Alarm: Stack Over Temperature	Piezo stack temperature exceeds operating limits	Reduce the operating frequency of the valve.
System Alarm: Piezo Driver FAULT	Piezo driver exceeds operating limits	Reduce the operating frequency of the valve. Switch off the controller and wait 5 seconds for the valve to fully discharge. Disconnect and reconnect all cables to the controller, then switch on the controller. If a system restart does not correct the problem, contact Nordson EFD. If RAMP is not selected for the open and close WAVE PROFILE settings, verify that the selected profile is correctly programmed.
	Clogged filter	Clean or replace the filter. Refer to the illustration provided under "Filter" on page 43.

Continued on next page

Troubleshooting (continued)

Problem	Possible Cause	Corrective Action
System Alarm: Pulse Time Adjusted	System running in remote mode faster than programmed parameters	If running the system in the external mode: <ul style="list-style-type: none"> • Verify that the length of the initiate signal is greater than the programmed RAMP > OPEN profile time. • Verify that the CYCLE time is greater than the programmed RAMP > OPEN / CLOSE profile times.
	PULSE time exceeds operating limits	The PULSE time is less than the RAMP > OPEN profile time. Correct the PULSE setting. The programmed RAMP > OPEN profile time is greater than the PULSE time. Correct the RAMP > OPEN profile time.
	CYCLE time exceeds operating limits	The CYCLE time entered is less than the programmed RAMP > OPEN and CLOSE times combined. Correct the CYCLE setting.
	Profile settings (RAMP > OPEN / CLOSE times) incorrectly programmed	The programmed RAMP > OPEN / CLOSE profile times are less than the PULSE / CYCLE times. Correct the RAMP > OPEN / CLOSE profile times.
System Alarm: Driver Shut Off	System running in remote mode faster than programmed parameters	If running the system in the external mode: <ul style="list-style-type: none"> • Verify that the length of the initiate signal is greater than the programmed RAMP > OPEN profile time. • Verify that the CYCLE time is greater than the programmed RAMP > OPEN / CLOSE profile times. • Verify that the signal is absolutely a clean, bounce-free signal.
	System (valve) running faster than 1000 Hz	Reduce the operating frequency of the valve. If a Driver Shut Off alarm continues to occur, contact Nordson EFD
	Damaged valve	Replace the valve.
System Alarm: Valve Communications Error	Loose or damaged cable / connection	Verify that both valve input cables are connected. Check the integrity of the cables and connections.
	Damaged valve	Replace the valve.
System Alarm: Heater Fault	Failed heater or shorted RTD in the valve	Switch off the controller and wait 5 seconds for the valve to fully discharge, then switch on the controller. If a system restart does not correct the problem, refer to the troubleshooting section of the valve manual. If a Heater Fault alarm continues to occur, contact Nordson EFD.

Technical Data

Input / Output Port Pin Descriptions

I/O 1 15-Position D-Sub

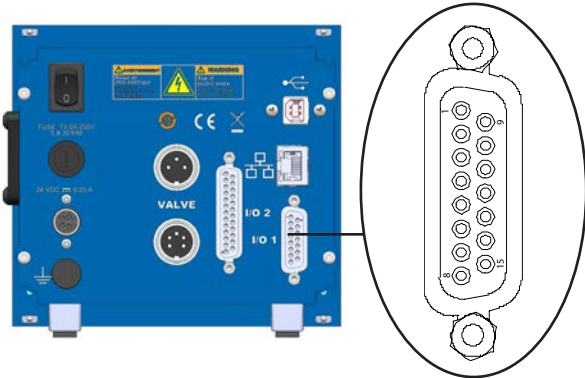

Pin Number	Pin Name	Direction	Level	Description
1	Remote Temperature Setting	Input	0–10V	<ul style="list-style-type: none"> Analog input for temperature adjustment 0–100° C (no cooling possible) 1 volt = 10° C Input impedance 40KΩ
2	Analog Ground			Ground for temperature adjustment
3	USET (Voltage Initiate)	Input	0–24V	<ul style="list-style-type: none"> Programmed dispensing parameters start (must be a clean, bounce-free signal) Input impedance 35KΩ <p>NOTES:</p> <ul style="list-style-type: none"> In the Continuous mode, dispensing occurs when this signal is ON; the controller also executes the values entered for Pulse (valve open time) and Cycle (time between deposits). In the Timed mode, when this signal rises the controller actuates the number of deposits entered for Count while also executing the values entered for Cycle (time between deposits) and Pulse (valve open time). In the External mode, any values entered for Cycle and Pulse are ignored and, when this signal rises, one dispense cycle occurs. This allows precise control of each deposit.
4	GND			Ground for inputs and outputs
5	Status of Temperature	Output	0–24V	Status of output temperature, comparison of actual and target temperature: <ul style="list-style-type: none"> 0V = Target temperature not reached 24V = Target temperature reached (temperature within 6° C) <p>NOTE: Use the remote communication capability to change the target temperature window. Refer to the "trng" command in the "Temperature" table in "Appendix A, Remotely Operating the Controller" on page 53.</p>

Continued on next page

Input / Output Port Pin Descriptions (continued)

I/O 1 15-Position D-Sub (continued)

Pin Number	Pin Name	Direction	Level	Description
6	Error Reset	Input	0–24V	<p>Default: Error Reset (signal to reset error or alarm condition remotely)</p> <p>Option: Remote Valve Power On/Off Control</p> <ul style="list-style-type: none"> • 0V = Valve Power OFF • 24V = Valve Power ON <p>Option: Valve Purge Control</p> <ul style="list-style-type: none"> • 0V = Valve Purge OFF • 24V = Valve Purge ON <p>NOTE: Use the remote communication capability to change the default pin function to Remote Valve On/Off Control or Valve Purge Control. Refer to "Configuration" under "Appendix A, Remotely Operating the Controller" on page 53.</p>
7	Power	Output	0–24V	<p>Status signal to identify controller status:</p> <ul style="list-style-type: none"> • 0V = Controller OFF • 24V = Controller ON
8	Pulse Out	Output		Nordson EFD use only
9	Warn Over Temperature	Output	0–24V	<p>Valve piezo actuator has exceeded its operating temperature limits:</p> <ul style="list-style-type: none"> • 0V = Valve piezo actuator temperature exceeded • 24V = Valve piezo actuator temperature within range
10	Analog Ground			Ground for temperature adjustment
11	Temperature Out	Output	0–10V	Analog temperature output: 1 volt = 10° C
12	Temperature Off	Input	0–24V	<p>Default: Temperature Off (valve heater control)</p> <ul style="list-style-type: none"> • 0V = Heater mode ON • 24 VDC = Heater Mode OFF <p>Option: Remote Valve Power On/Off Control</p> <ul style="list-style-type: none"> • 0V = Valve Power OFF • 24V = Valve Power ON <p>Option: Valve Purge Control</p> <ul style="list-style-type: none"> • 0V = Valve Purge OFF • 24V = Valve Purge ON <p>NOTE: Use the remote communication capability to change the default pin function to Remote Valve On/Off Control or Valve Purge Control. Refer to "Configuration" under "Appendix A, Remotely Operating the Controller" on page 53.</p>
13	Error Out	Output	0–24V	<p>Status signal indicating that an error or alarm condition has occurred:</p> <ul style="list-style-type: none"> • 0V = Error or alarm condition active • 24V = No error or alarm condition detected

Continued on next page

Input / Output Port Pin Descriptions (continued)

I/O 1 15-Position D-Sub (continued)

Pin Number	Pin Name	Direction	Level	Description
14	Pulse OK	Output	0-24V	<p>End of Cycle feedback indicating that the programmed dispense parameters have completed.</p> <p>The PULSE OK signal is generated after each programmed dispensing parameter has occurred. The signal can be used for monitoring and counting.</p> <ul style="list-style-type: none"> • 0V = No dispensing active • 24V (6 ms) = Dispensing has occurred <p>The signal duration of 6 ms is the factory default. The signal duration is adjustable from 1-100 (ms). Refer to the System PULSE OK Time setting under "SYSTEM Screens" on page 26.</p>
15	Ext 24 Volts	Input/output	24V	<p>The controller can provide up to 200 mA as a courtesy power supply or this pin can be used to provide an external isolated power supply. Use the "dioe" and "diov" commands to configure the functionality of this pin (Refer to "Appendix A, Remotely Operating the Controller" on page 53). Contact Nordson EFD for applications which require more than 200 mA.</p>

I/O 2 25-Position D-Sub

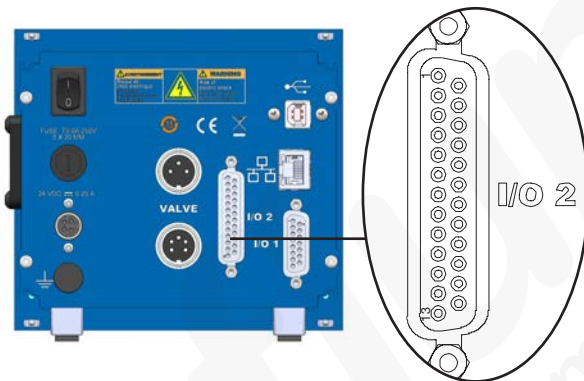

Pin Number	Pin Name	Direction	Level	Description
1	Not available			Nordson EFD use only
2	RS_232_TX	Output	0-5V	Transmission pin for RS232. Contains response data from controller.
3	RS_232_RX	Input	0-5V	Receiving pin for RS232. Data from an RS232 device inputs to this pin to command the controller. Refer to "Appendix A, Remotely Operating the Controller" on page 53 for instructions.
4	Not available			Nordson EFD use only
5	Not available			Nordson EFD use only

Continued on next page

Input / Output Port Pin Descriptions (continued)

I/O 25-Position D-Sub (continued)

Pin Number	Pin Name	Direction	Level	Description
6	Not available			Nordson EFD use only
7	DGND			Internal non-isolated ground for use with RS232
8	Not available			Nordson EFD use only
9	Not available			Nordson EFD use only
10	Not available			Nordson EFD use only
11	Not available			Nordson EFD use only
12	Not available			Nordson EFD use only
13	DGND			Internal non-isolated ground for use with RS232
14	Not available			Nordson EFD use only
15	DGND			Internal non-isolated ground for use with RS232
16	Not available			Nordson EFD use only
17	DSUB_GND			External ground
18	Not available			Nordson EFD use only
19	DSUB_GND			External ground
20	Not available			Nordson EFD use only
21	DSUB_GND			External ground
22	Not available			Nordson EFD use only
23	Not available			Nordson EFD use only
24	Not available			Nordson EFD use only
25	Ext 24 Volts	Input/output	24V	The controller can provide up to 200 mA as a courtesy power supply or this pin can be used to provide an external isolated power supply. Use the "dioe" and "dloi" commands to configure the functionality of this pin (Refer to "Appendix A, Remotely Operating the Controller" on page 53). Contact Nordson EFD for applications which require more than 200 mA.

Wiring Diagrams

PICO Touch Controller Inputs

- All inputs are 0–12V OFF, 15–24V ON.
- When ON, the current draw is 18 mA per pin at 24V, showing about 1.3 kΩ input resistance.

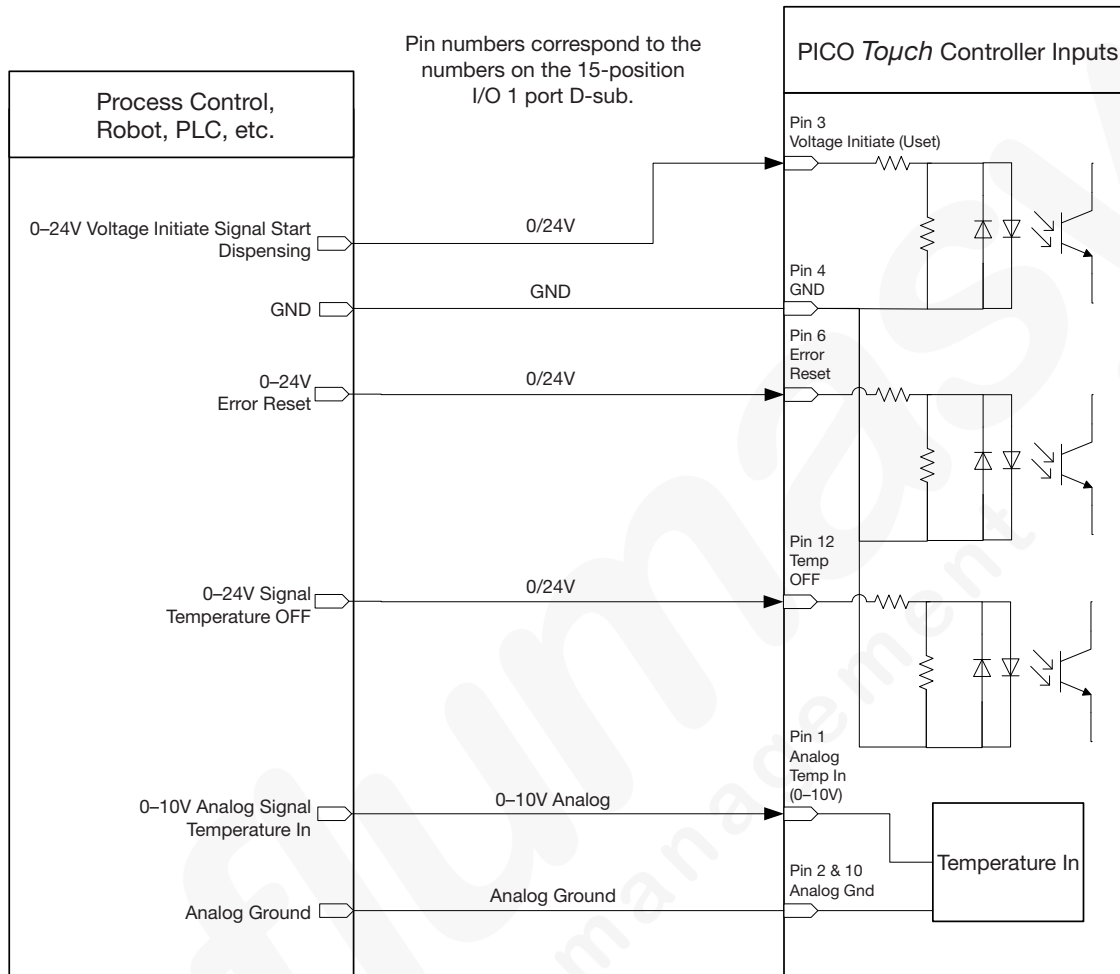

Wiring Diagrams (continued)

PICO Touch Controller Outputs

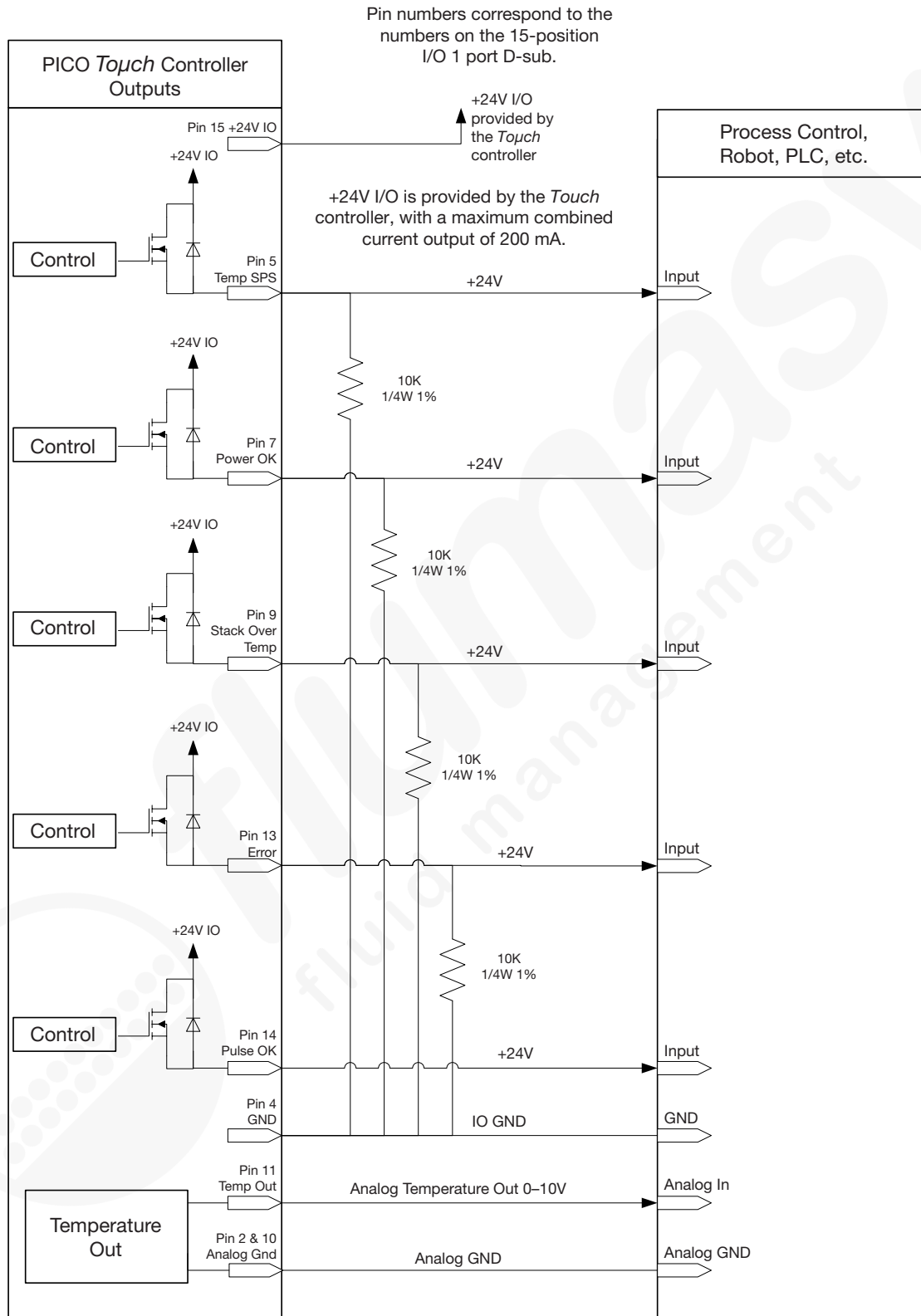

Wiring Diagrams (continued)

PICO Touch Controller and PICO Controller 2+2-XCH-V3

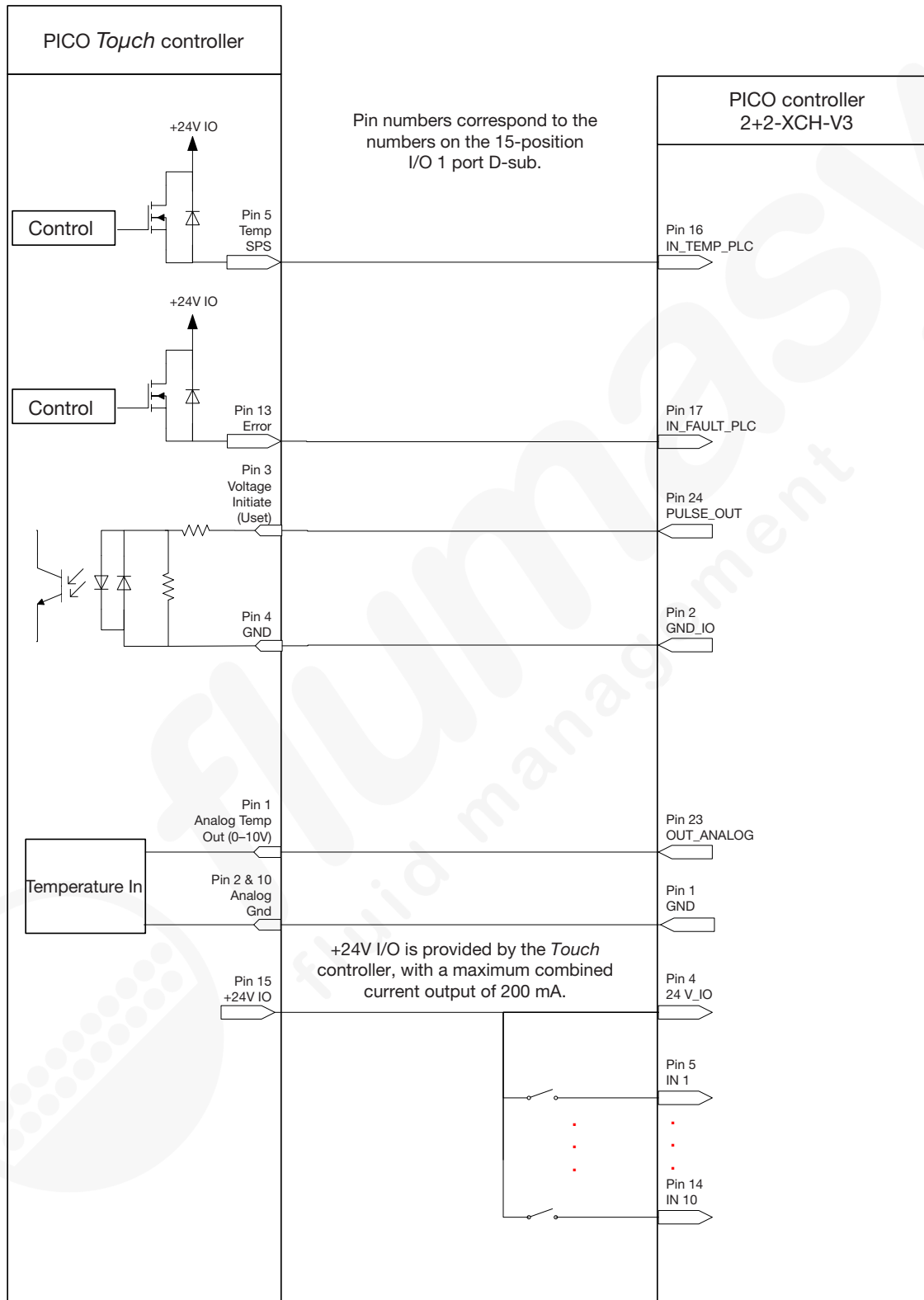

Appendix A, Remotely Operating the Controller

You can operate the controller through a personal computer (PC) using the supplied USB communication cable or by connecting to the RS232 connection through the 25-pin D-sub (port I/O 2). Communicating in this manner allows you to modify dispensing parameters remotely and also to load custom wave profiles on the controller.

Connection Using a PC

Connect the USB cable to the USB port on the back of the controller and to a PC.

Connection Using RS232

The 25-pin D-sub (port I/O 2) is configured for use with a null modem cable. Alternatively, use the I/O 2 port RS232 pins (pins 2 and 3) to make your connection. Refer to "I/O 2 25-Position D-Sub" on page 48 for the I/O 2 port pin descriptions.

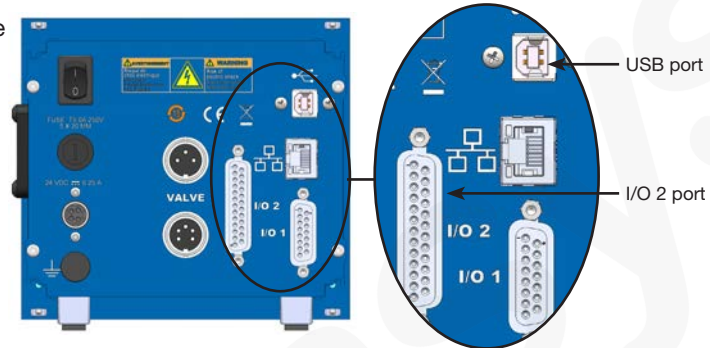

Communication Specifications

The controller acts as a terminal to the remote host PC. The controller communicates using the following settings:

- Synchronous mode: half duplex
- Baud rate: 115200
- Start bit: 1
- Data length: 8 bit (ASCII)
- Parity bit: None
- Stop bit: 1

Communication Sequence

The host machine initiates all communication sequences. The controller evaluates the last four characters in the command packet as the command.

Typical Command Packet: xxxCCCC
(where xxx is the setting and CCCC is the command)
The length of the setting varies depending on the command.

Serial Commands

Commands are evaluated after a return (Enter key or 0x0D hex). After a return is received, the controller evaluates the command, transmits any data related to the command, and closes the packet with <3.

The following tables provide the commands for the controller. Each entry includes a brief description of the command, shows the command format, and provides a description of the data that is attached and retrieved by the command.

NOTES:

- The <3 acknowledge command is removed from the examples since all commands are successfully evaluated.
- The return constant (Enter key: ↵) is depicted as [Enter] in all examples.

Appendix A, Remotely Operating the Controller (continued)

Valve (Driver)

Command	Description	Command Format	Sample, with Output After [Enter]
drv1	Sets the valve mode (MODE)	x=1-5 Where x equals: 1drv1 Sets MODE to Timed 2drv1 Sets MODE to Purge 3drv1 Sets MODE to Continuous 5drv1 Reads the current mode	1drv1 [Enter] Driver 1: TIME 2drv1 [Enter] Driver 1: PURG 3drv1 [Enter] Driver 1: CONT 5drv1 [Enter] Driver 1: CONT
dcn1	Sets the valve dispense count (COUNT)	xxxxxdcn1 Where x = > 00001-65535 counts (DCNT)	00001dcn1 [Enter] Dispense Count (DCNT) = 00001
ont1	Sets the valve ON time (PULSE)	xxxx.xxont1 Where xxxx.xx = ON time in ms NOTE: Time is entered as an ON / OFF time where ON = PULSE and Cycle = ON + OFF. ON and OFF times should be adjusted together to preserve the Cycle time setting.	0001.45ont1 [Enter] Time Set To = 0001.45 ms
oft1	Sets the valve OFF time (CYCLE) (Where OFF time + ON Time = CYCLE)	xxxx.xxoft1 Where xxxx.xx = OFF time in ms NOTE: Time is entered as an ON / OFF time where ON = PULSE and Cycle = ON + OFF. ON and OFF times should be adjusted together to preserve the Cycle time setting.	0005.00oft1 [Enter] Time Set To = 0005.00 ms
rdr1	Returns the valve status	rdr1	rdr1 [Enter] MODE: TIME PULSE: 0001.45ms CYCLE: 0006.45ms COUNT: 00002 Profile Rise.: 1 Profile Fall.: 1 Stroke: 0045 Up Ramp Time: 000.250ms Dwn Ramp Time: 000.250ms Close Voltage: 100 Num Shots: 0015731319 Power Mode: Default

Continued on next page

Appendix A, Remotely Operating the Controller (continued)

Valve (Driver) (continued)

Command	Description	Command Format	Sample, with Output After [Enter]
cycl	Cycles the valve (mimics the CYCLE icon on the touchscreen)	0cycl Cycle OFF 1cycl Cycle ON NOTE: Each Cycle ON command must be followed by a Cycle OFF command.	1cycl [Enter] Cycle: ON 0cycl [Enter] Cycle: OFF
dpwr	Sets the valve power control	0dpwr Valve power OFF 1dpwr Valve power ON	0dpwr [Enter] Valve Driver Power: OFF 1dpwr [Enter] Valve Driver Power: ON
plok	Sets the duration of the PULSE OK TIME I/O pin output	AAAplok Where AAA = PULSE OK TIME in ms	050plok [Enter] Pulse OK Time Adj:050
drvo	Sets the driver configuration at power up to ON	drvo	drvo [Enter] Power Mode: On at boot up
drvf	Sets the driver configuration at power up to OFF (default)	drvf	drvf [Enter] Power Mode: Default
sdr1	Sets OPEN, CLOSE, and COUNT in one command	xxxx.xx,yyyy.yy,zzzzsdr1 Where xxxx.xx is the OPEN time (in ms) Where yyyy.yy is the CLOSE time (in ms) Where zzzz is COUNT	0002.23,0005.77,00535sdr1 [Enter] 0002.23,0005.77,00535

Appendix A, Remotely Operating the Controller (continued)

Temperature

Command	Description	Command Format	Sample, with Output After [Enter]
chtr	Sets the heater mode	xchtr Where x equals: 0chtr Disables the corresponding channel 1chtr Enables the corresponding channel 2chtr Reads back the status (enabled / disabled) of the corresponding channel 3chtr Sets the heater mode to remote	0chtr [Enter] Heater Channel: 1 OFF 1chtr [Enter] Heater Channel: 1 ON 2chtr [Enter] Heater Channel: 1 ON 3chtr [Enter] Heater Channel: REM
stmp	Sets the heater temperature setpoint	DDD.Dstmp Where DDD.D = temperature setting in degrees C NOTE: Temperature must be entered in °C.	045.9stmp [Enter] Set Temperature = 045.9C
rhtr	Returns the heater status	rhtr	<3rhtr [Enter] MODE = OFF SET = 055.3C ACT = 031.5C STACK = 031.1C
trng	Sets the adjustable temperature range limit for I/O 1 pin 5 (Status of Temperature)	DD.Dtrng Where DD.D = temperature range limit for pin 5 (0.5–12.0° C) NOTES: • Default is 6° C. • Temperature must be entered in °C.	06.5trng [Enter] Temp Range = 06.5C
rrng	Reads the adjustable temperature range limit for I/O 1 pin 5 (Status of Temperature)	rrng	rrng [Enter] Temp Range 0000000000000=6.5C

Appendix A, Remotely Operating the Controller (continued)

Profile

Command	Description	Command Format	Sample, with Output After [Enter]
rzpr	Sets the close (rise) profile of the valve	Xrzpr Where X = selections 1–6	6rzpr [Enter] Profile: 6
flpr	Sets the open (fall) profile of the valve	Xflpr Where X = selections 1–6	6flpr [Enter] Profile: 6
strk	Sets the stroke of the valve	AAAstrk Where AAA = stroke adjustment in volts NOTE: Only valid in Ramp mode.	075strk [Enter] Stroke Adjusted: 075
volp	Sets the close voltage of the valve	AAAvolp Where AAA = close voltage NOTE: Only valid in Ramp mode.	095volp [Enter] Voltage Adjust: 095
clst	Sets the close (rise) time of the valve	AAAAclst Where AAAA = close time in μ s NOTE: Only valid in Ramp mode.	0300clst [Enter] Profile Time Adj: 0300
opnt	Sets the open (fall) time of the valve	AAAAopen Where AAAA = open time in μ s NOTE: Only valid in Ramp mode.	0220opnt [Enter] Profile Time Adj: 0220

Configuration

Command	Description	Command Format	Sample, with Output After [Enter]
cfg1	Configures I/O 1 pin 6 for Error Reset (default), Valve Power On/Off Control, or Valve Purge Control NOTE: If pin 6 is set to Valve Power On / Off Control, the drvf command must be used. Refer to drvf under "Valve (Driver)" on page 54.	0cfg1 Sets pin 6 to Error Reset (default)	0cfg1 [Enter] Input Configuration... Pin 6 = Error Reset Pin 12 = Temperature Off
		1cfg1 Sets pin 6 to Valve Power On/Off Control	1cfg1 [Enter] Input Configuration... Pin 6 = Valve Power On/Off Control Pin 12 = Temperature Off
		2cfg1 Sets pin 6 to Valve Purge Control	2cfg1 [Enter] Input Configuration... Pin 6 = Valve Purge Control Pin 12 = Temperature Off
cfg2	Configures I/O 1 pin 12 for Temperature Off (default), Valve Power On/Off Control, or Valve Purge Control NOTE: If pin 12 is set to Valve Power On / Off Control, the drvf command must be used. Refer to drvf under "Valve (Driver)" on page 54.	0cfg2 Sets pin 12 to Temperature Off (default)	0cfg2 [Enter] Input Configuration... Pin 6 = Error Reset Pin 12 = Temperature Off
		1cfg2 Sets pin 12 to Valve Power On/Off Control	1cfg2 [Enter] Input Configuration... Pin 6 = Error Reset Pin 12 = Valve Power On/Off Control
		2cfg2 Sets pin 12 to Valve Purge Control	2cfg2 [Enter] Input Configuration... Pin 6 = Error Reset Pin 12 = Valve Purge Control

Continued on next page

Appendix A, Remotely Operating the Controller (continued)

Configuration (continued)

Command	Description	Command Format	Sample, with Output After [Enter]
rcfg	Reads the current configuration settings for I/O 1 pins 6 and 12	rcfg	rcfg [Enter] Input Configuration... Pin 6 = Error Reset Pin 12 = Valve Purge Control
dioi	Sets the following pins to an internally provided (non-isolated) signal: <ul style="list-style-type: none"> I/O 1 pin 4 (GND) and pin 15 (Ext 24 Volts) I/O 2 pins 17, 19, and 21 (DSUB_GND) and pin 25 (+25). NOTE: Use this setting to configure an Ext 24 Volt pin as a courtesy power supply.	dioi	dioi [Enter] Voltage = Internal
dioe	Sets the following pins to an externally provided (non-isolated) signal: <ul style="list-style-type: none"> I/O 1 pin 4 (GND) and pin 15 (Ext 24 Volts) I/O 2 pins 17, 19, and 21 (DSUB_GND) and pin 25 (+25). NOTE: Use this setting to configure an Ext 24 Volts pin as an externally provided source for the optically isolated inputs / outputs.	dioe	dioe [Enter] Voltage = External
rlay	Reads the current settings (as set using the dioi and dioe commands) for the following pins: <ul style="list-style-type: none"> I/O 1 pin 4 (GND) and pin 15 (Ext 24 Volts) I/O 2 pins 17, 19, and 21 (DSUB_GND) and pin 25 (+25). 	rlay	rlay [Enter] Voltage = Internal

Appendix A, Remotely Operating the Controller (continued)

Other

Command	Description	Command Format	Sample, with Output After [Enter]
info	Displays the controller and valve Information	info	<pre> info [Enter] PICO Touch: 01.03 PCB Serial Number: WV080515 Serial Number: 828828 Valve Serial Number: 829829 Valve FW Rev: 99.04 Valve PCB Rev: 01 Valve Type: SD-7361218 </pre>
rals	Retrieves the last 40 (0–39) alarm conditions that occurred; includes time and alarm name	rals	<pre> rals [Enter] Current Error #: 30 Code # 00 Time: 00005 Code: Piezo Driver Fault Code # 01 Time: 00005 Code: Piezo Driver Fault : : Code # 39 Time: 00005 Code: Piezo Driver Fault </pre>
stat	Returns the system status (active alarms) as a bitmap or SYS OK when there are no alarms	stat	<pre> stat [Enter] Alarm:0x90 or stat [Enter] SYS OK </pre>
arst	Resets a currently active alarm	arst	<pre> arst [Enter] </pre>

NORDSON EFD ONE YEAR LIMITED WARRANTY

Nordson EFD products are warranted for one year from date of purchase to be free from defects in material and workmanship (but not against damage caused by misuse, abrasion, corrosion, negligence, accident, faulty installation or by dispensing material incompatible with equipment) when the equipment is installed and operated in accordance with factory recommendations and instructions. Nordson EFD will repair or replace free of charge any part of the equipment thus found to be defective, on authorized return of the part prepaid to our factory during the warranty period. In no event shall any liability or obligation of Nordson EFD arising from this warranty exceed the purchase price of the equipment. This warranty is valid only when oil-free, clean, dry, filtered air is used.

Nordson EFD makes no warranty of merchantability or fitness for a particular purpose. In no event shall Nordson EFD be liable for incidental or consequential damages.

