

725HF-SS and 725HF-A Piston Valves

Maintenance & Parts Guide

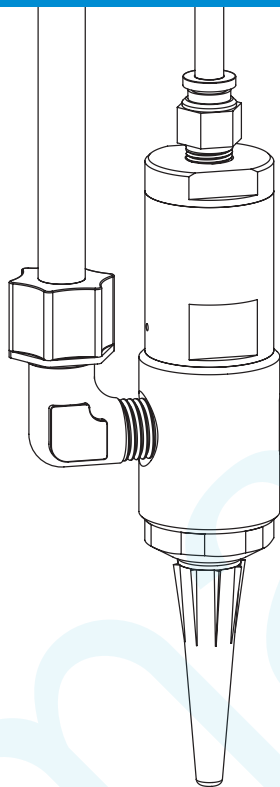

IMPORTANT!
Save this Sheet.

Forward to
Maintenance or
Tool Crib Supervisors

Electronic pdf files of Nordson EFD
manuals are also available at
nordsonefd.com



Valve Disassembly and Reassembly Procedures

⚠ CAUTION

To prevent damage, the valve must be disassembled starting at the fluid outlet end of the valve.

1. Put threaded rod in mounting hole.
2. Remove body cap.
3. Remove sealing head. *
4. With a wrench on the flats of the air cylinder body, turn to loosen fluid body.
5. Remove fluid body. *
6. Remove input air hose from push-in fitting on air cap.
7. Insert 1/8" hex wrench through air inlet hole in cap and turn shaft, locking screw out two turns. *

8. Using the hex on the shaft, unthread shaft, and remove shaft and diaphragm. *
9. Unscrew air cylinder cap from air cylinder body. *
10. Remove piston and spring.

NOTE: Before reassembling valve, clean all parts, replace O-rings, sealing head and diaphragm. Inspect for damaged threads, piston pins for straightness and fluid body seat for pitting.

⚠ CAUTION

Do not thread fluid inlet fittings too far into the valve. Doing so can obstruct the piston shaft, causing leakage, poor dispensing performance, and damage to the valve.

Reassemble the valve in reverse order of disassembly. Lubricate parts indicated with Nye Lubricant #865 included in the General Maintenance Kit.

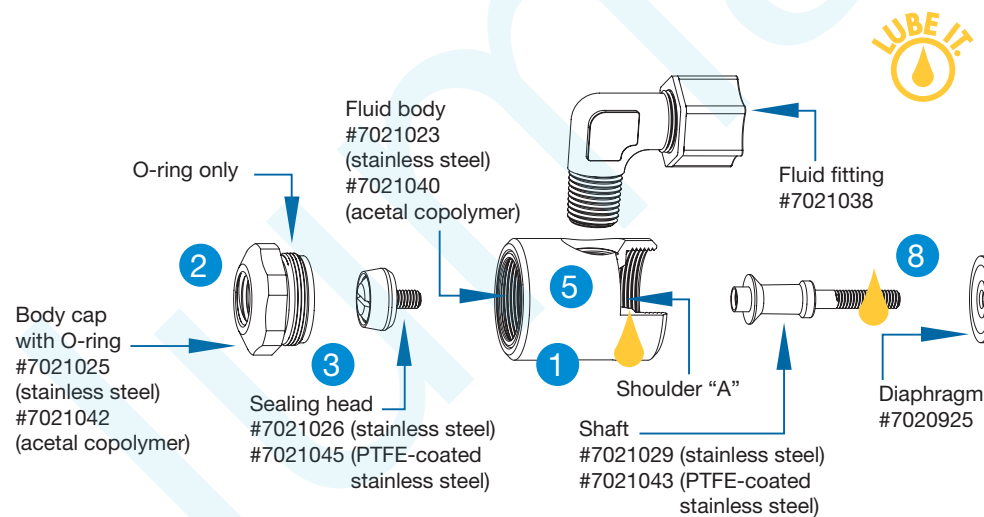

General Maintenance Kit

#7021019 for 725HF-SS (7021020) valve
#7021016 for 725HF-A (7021015) valve†

Includes air cylinder and body cap O-rings, diaphragm, sealing head with screw and lubricant.

† Repair kit for 725HF-A valve also includes PTFE-coated sealing-head screws.

Maintenance Tools:

1/8" hex wrench
1/4" flat-tip screwdriver
3/8" box wrench
7/8" open-end wrench
8" adjustable wrench
1/4" NPT male pipe or rod

step	part	newton meters	(inch pounds)
3	Sealing head screw	1.69 Nm	(15 inch pounds)
5	Stainless steel fluid body	10.8 - 13.6 Nm	(8 - 10 foot pounds)
5	Acetal fluid body	.033 Nm	(.30 inch pounds)
7	Shaft locking screw	2.82 Nm	(25 inch pounds)
8	Shaft	1.69 Nm	(15 inch pounds)
9	Air cylinder cap	10.8 Nm	(8 foot pounds)

*Parts that require a specific torque when reassembling the valve.

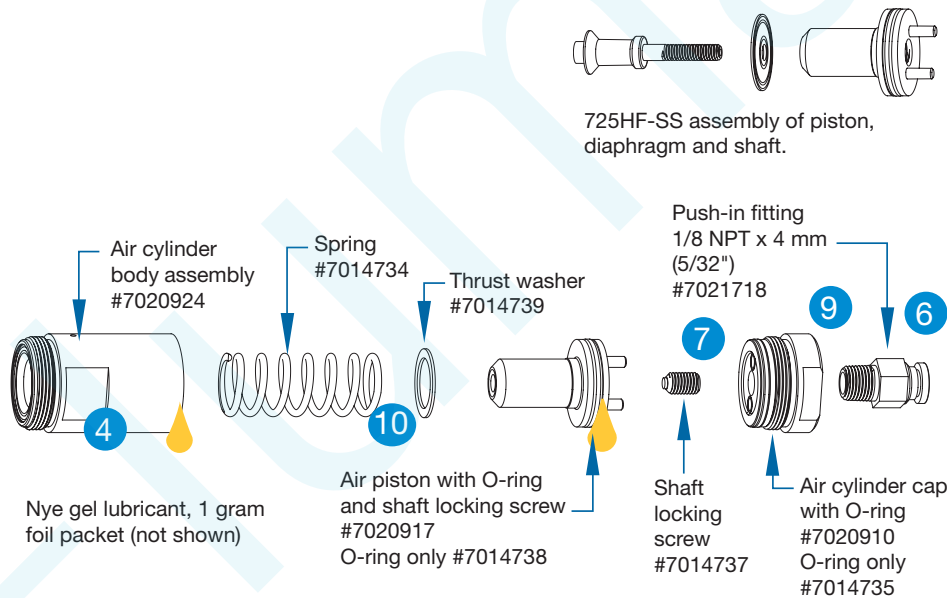

Troubleshooting Guide

No fluid flow

- If valve operating air pressure is too low, the valve will not open. Increase air pressure to 4.8 bar (70 psi) minimum.
- The reservoir air pressure may not be high enough. Increase pressure.
- The dispensing nozzle may be clogged. Replace nozzle.
- Fluid may have solidified in the fluid body. Clean the fluid body.

Fluid drools after the valve closes, eventually stopping

- This is caused when air is trapped in the outlet section of the fluid body or the fluid has entrapped air. The air will expand after the valve closes, causing extrusion until the air reaches atmospheric pressure.
- Purge the valve by dispensing at a steady flow until clear. If a small tip is used, it may be necessary to remove the tip while purging to obtain sufficient flow to carry the air down through the tip adapter.
- If the fluid has entrapped air, the material must be degassed before dispensing.

NOTE: For stripes and lines, input air pressure can be lowered to eliminate opening surge.

Fluid drips at a steady rate after the valve closes

- A steady drip indicates failure of the sealing head to close fully due to particle build-up or wear. In either case, replace the sealing head in accordance with the maintenance instructions.
- Fluid leakage can also occur when a fluid inlet fitting is threaded too far into the valve, thus obstructing the piston shaft. Ensure that the fluid inlet fitting is properly installed.

Valve responds slowly when opening and closing

- Valve response is related to control air hose length and size. The valve is supplied with 5-feet of 4 mm (5/32") tubing attached. Any additional length or size change will affect response time. Check to be sure the length and size have not been changed.

Fluid flows out of the drain hole

- Fluid flowing out of the drain hole indicates a ruptured diaphragm. Replace in accordance with the maintenance instructions.

Inconsistent deposits

- Inconsistent deposits can result if the air pressure controlling the valve and/or supplying the reservoir is fluctuating or if the valve operating pressure is less than 4.8 bar (70 psi). Check to be sure air pressures are constant and the valve operating pressure is 4.8 bar (70 psi).
- The time the valve is open must be constant. Check to be sure the valve controller is providing a consistent output.

