

Precision valve system for consistent microdot application.

epoxies lubricants marking inks solvents uv-cure & light-cure adhesives



Electronic pdf files of Nordson EFD manuals are also available at www.nordsonefd.com

The MicroDot valve system incorporates a pneumatically operated adjustable needle valve designed to apply very precise deposits down to fractions of a microliter.

This system is ideal for automated assembly processes that require small dispensing tips ranging in size from 22 to 33 gauge. The 741MD-SS valve has an adjustable needle stroke with a unique calibration feature that allows the user to maintain exact deposit size.



Features

- Consistent microdots as small as 0.18 mm (0.007") diameter
- Unaffected by entrapped air in fluid
- Easy calibration; short setup time
- Drip-free shutoff
- Cycle rate exceeds 400/minute
- **Zero dead fluid volume**
- Low-maintenance design



MicroDot valve systems



The complete system includes the 741MD-SS dispense valve, Nordson EFD ValveMate™ 8000 controller, the fluid reservoir and dispense tip.

Expert technical assistance and high quality standards ensure productive, trouble-free performance. Nordson EFD offers a full line of reliable dispensing systems to meet your specific application requirements.

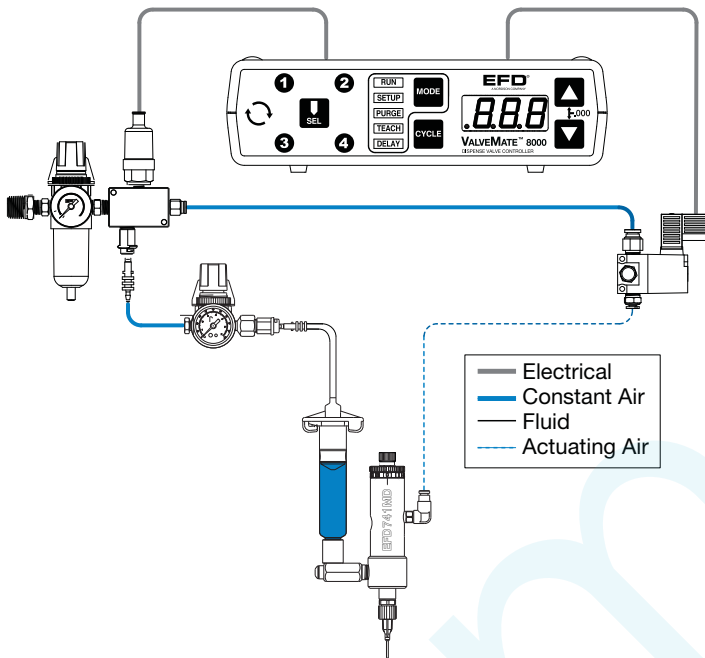

741MD-SS Valve

The unique design of the 741MD-SS needle valve ensures extremely fine deposit control. The stainless steel shutoff needle seats in the hub of the dispensing tip rather than the valve body. This design minimizes dead fluid volume by having fluid cutoff occur as close as possible to the dispensing orifice.

Because the needle seat is part of the dispense tip itself, the seat can be renewed by simply replacing the disposable tip.

Size: 127.5 mm x 26.9 mm (5.02" x 1.06" diameter)

Weight: 251 grams (9.0 oz)

Actuating air pressure required: 70 psi (4.8 bar)

Maximum fluid pressure: 100 psi (6.9 bar)

Fluid inlet thread: 1/8 NPT female

Fluid outlet: Luer taper with retaining nut

Mounting: 1/4-28 UNF tapped hole

Cycle rate: Exceeds 400 per minute

Air cylinder body: Hard-coated aluminum

Fluid body: Type 303 stainless steel

Piston: Type 303 stainless steel

Needle: Type 303 stainless steel

Tip adapter: Type 303 stainless steel

EFD SafetyLok™ collar: Hard-coated aluminum

All stainless steel parts are passivated.

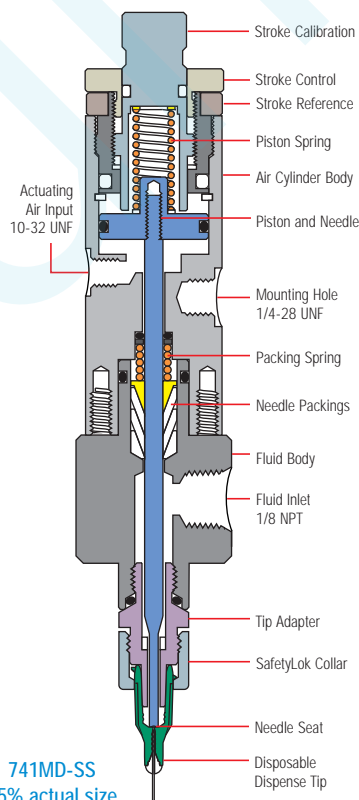

741MD-SS
75% actual size

ValveMate 8000 Controller

Valve open time is the primary control of deposit size. The ValveMate controller puts push-button adjustment of valve open time where it needs to be — at the valve.

- Partner to Programmable Logic Controller (PLC)
- Easy deposit size control
- Increased production output
- End user convenience
- Maximum machine efficiency

Automation: XYZ & XYZR Robot Dispensing Systems

Nordson EFD offers a wide selection of XYZ and XYZR robot systems that are fully compatible with ValveMate valve controller systems. Consistent, accurate, repeatable and complex dispensing applications can be easily performed with EFD robots, with working envelopes that range from 200 x 200 x 50mm to 510 x 510 x 100mm. Scara robot systems are also available for larger, heavier products or inline dispensing applications.

Fluid Reservoirs

Choose from clear syringe barrels for normal fluids, amber for UV-cure and light-sensitive fluids, and opaque black for complete light protection. Specify from the following (note: each box contains an equal number of syringe barrels and white PE pistons).

size	clear	light-block amber	opaque black	sets per box
3cc	5109CP-B	5109LBP-B	5109UP-B	50
5cc	5110CP-B	5110LBP-B	5110UP-B	40
10cc	5111CP-B	5111LBP-B	5111UP-B	30
30cc	5112CP-B	5112LBP-B	5112UP-B	20

Dispense Tips

Precision Ultra stainless steel tips are required to maintain microdot control. 741MD-SS Series valves are packaged with a kit of stainless steel tips in sizes from 22 to 32 gauge and 33 gauge chamfered tips.



Flumasys s.r.o.
info@flumasys.com