

782RA Series Radial Spray Valve

Uniform 360° coating of lubricants, primers, and other fluids

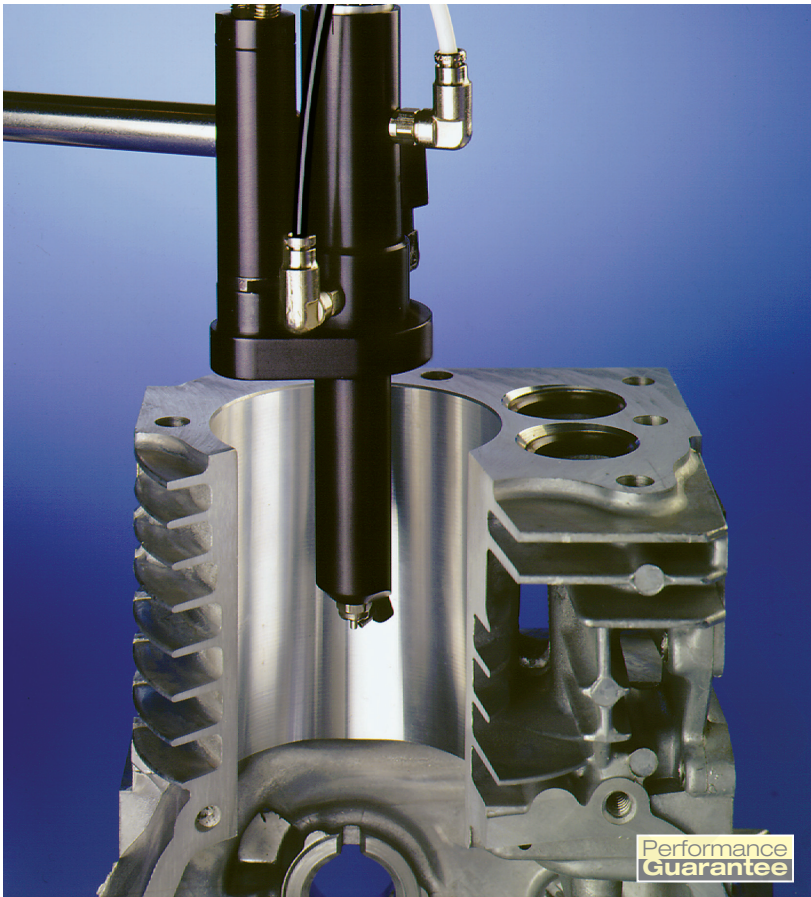

Unique 782RA Series air-actuated spray system applies uniform 360° coating of lubricants, primers, and other low-to-medium viscosity fluids inside cylinders 25.4 mm to 304.8 mm (1 in. to 12 in.) in diameter.

Low volume, low pressure (LVLP) air is used to atomize the fluid, while a precision air motor drives a rotating air cap, which produces the radial output.



Features

- Adjustable nozzle air
- High transfer efficiency
- No mist or overspray
- Self-adjusting PTFE packings
- Cycle rate exceeds 300/minute
- Adjustable fluid flow rate
- Low-maintenance design

Part Number	Description
7021649	782RA Radial Spray Valve)

Radial Spray Valve

The complete system includes the 782RA dispense valve, ValveMate™ 7160RA controller, and the fluid reservoir.

Expert technical assistance and high quality standards ensure productive, trouble-free performance. EFD offers a full line of reliable dispensing systems to meet your specific application requirements.

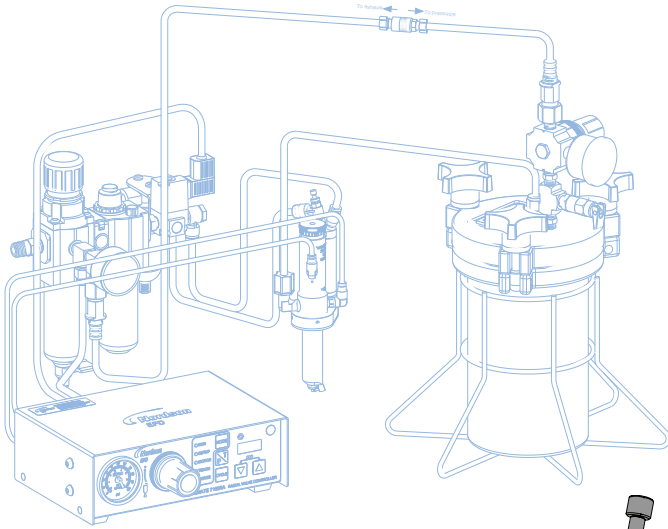

782RA Valve

The 782RA internal spray valve features a rotating head that produces a narrow radial spray without mist or overspray.

High transfer efficiency with instant fluid cutoff at the end of the spray cycle ensures that coatings are applied evenly from startup to shutdown.

Size: 174.5 mm x 53.8 mm diameter (6.87 in. x 2.12 in.)

Weight: 480.8 grams (16.9 oz)

Motor air consumption: <0.3 SCFM at 5.4 bar (80 psi)

Nozzle air consumption: 1.5 SCFM at 2.1 bar (30 psi)

Actuating air pressure required: 4.8 bar (70 psi)

Maximum fluid pressure: 20.7 bar (300 psi)

Fluid inlet thread: 1/8 NPT female

Mounting: 1/4-28 UNF tapped hole

Cycle rate: Exceeds 300 per minute

Air cylinder body: Hard-coated aluminum

Fluid body: Hard-coated aluminum

Piston: Type 303 stainless steel

Needle and nozzle: Stainless steel

Needle packings: PTFE

Rotor: Hard-coated aluminum

All-stainless-steel parts are passivated.

*Ultra High Molecular Weight polyethylene

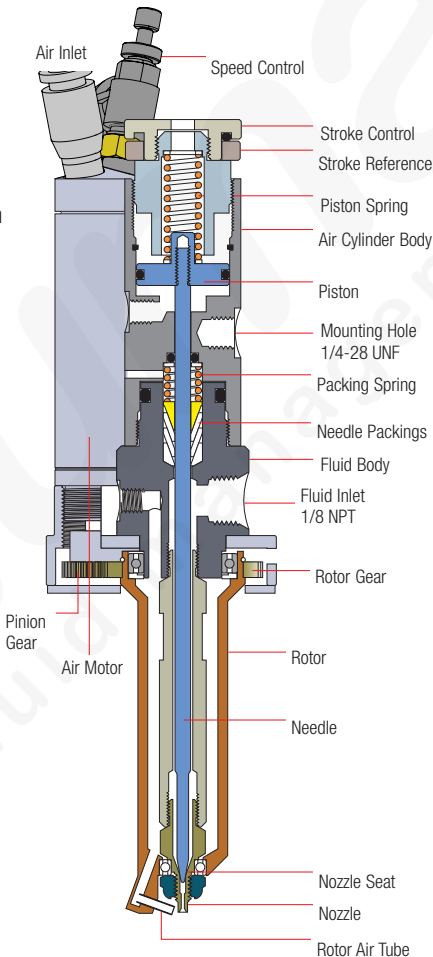

ValveMate 7160RA Controller

Valve open time is the primary control of deposit size. EFD ValveMate controllers put push-button adjustment of valve open time where it needs to be — at the valve. The ValveMate controller is a partner — not an alternative — to a programmable logic controller (PLC).

- Easy deposit size control
- Precise control of nozzle air pressure
- Increased production output
- End user convenience
- Maximum machine efficiency

Fluid Reservoirs

Nordson EFD reservoirs are supplied with precision, constant-bleed regulators to ensure consistent fluid pressure to the valve. Tank reservoirs are available in 1.0, 5.0, and 19.0 liter capacities. Cartridge sizes range from 2.5 to 32 ounces and provide a clean cutoff to prevent wicking and drips. Contact Nordson EFD to order a supply.

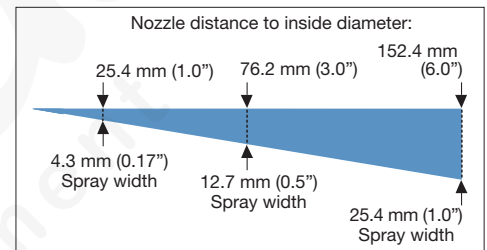

Automated Dispensing Systems

Nordson EFD automated dispensing systems deliver market-leading repeatability and accuracy in fluid placement and positioning. Specialized dispensing software simplifies setup and programming. Optimize dispensing results with features such as laser height sensing and smart vision CCD cameras.

Request a Process Evaluation

Contact Nordson EFD to configure a precision dispense system that meets your specific needs, with:

- A complimentary process evaluation by experienced fluid dispensing experts.
- Samples processed for customer evaluation and approval prior to purchase.



Flumasys s.r.o.
info@flumasys.com