

782RA Spray Valve

Installation Guide

Introduction

The 782RA is a precision, air-actuated spray valve that produces a narrow radial output ideal for coating the interiors of cylinders. Low volume, low pressure (LVLP) air is used to atomize the fluid, while a precision air motor drives a rotating air cap that produces the radial output.

The 782RA valve has a 5.6 cm (2.2 in.) extended rotor air cap that will reach inside cylinders with a minimum inner diameter of 2.5 cm (1.0 in.). The valve is simple to use and will operate many millions of cycles without maintenance.

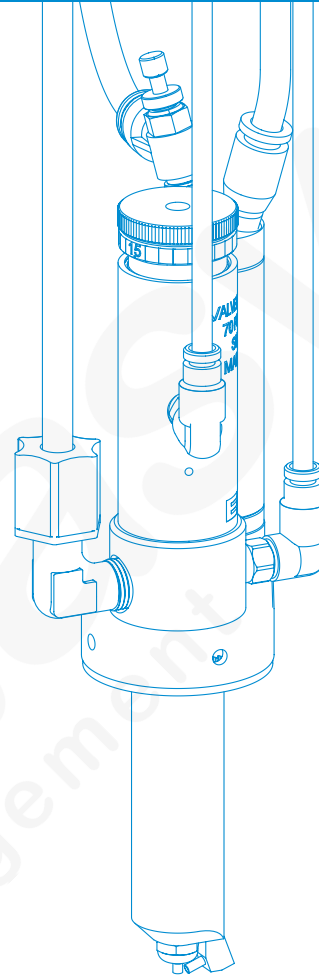
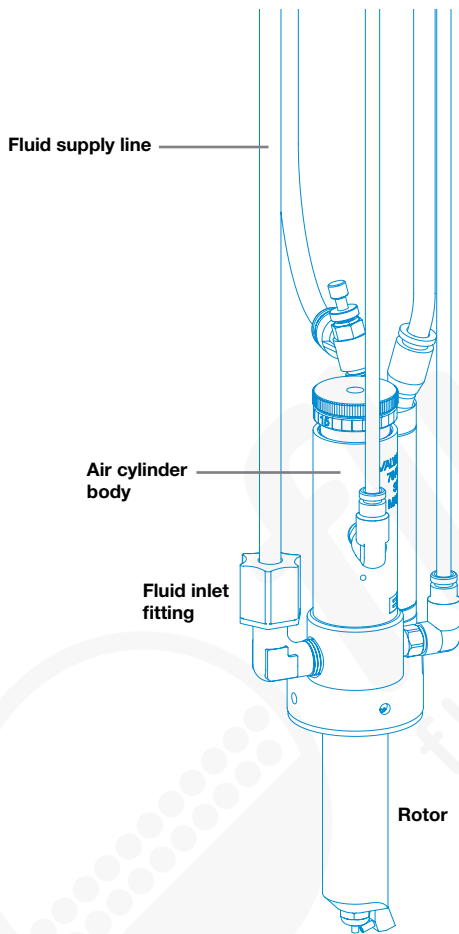

Installation

Prior to installing this valve, please read the associated reservoir and controller operating manuals to become familiar with the operation of all components of the dispensing system.

NOTE: Refer to the ValveMate™ 7160RA controller operating manual for air connection instructions.

1. Mount the valve using the 1/4-28 UNF tapped hole on the air cylinder body.
2. Connect the fluid feed hose to the reservoir outlet and to the valve inlet port using the appropriate fittings (supplied).
3. Connect the 4 mm diameter air hoses from the valve to the controller: white goes to the ACTUATING AIR port and black goes to the NOZZLE AIR port.
4. Connect the white and black 6 mm diameter air hoses to the air motor speed control: white connects to the motor speed control, and black connects to the F fitting (actual markings on air motor).
5. Connect the white and black 6 mm diameter hoses to the filter-regulator-lubricator assembly. White connects to the oil recovery bowl and black connects to the control valve.
6. Fill the fluid reservoir. After filling, secure the cover and connect the reservoir air pressure regulator to the air tee using the flexible air line (supplied). Attach the black male quick-connect on the air line to the reservoir regulator and then attach the white quick-connect to the air tee.
7. To pressurize the system, slide the shut-off valve on the air line toward the fluid reservoir.

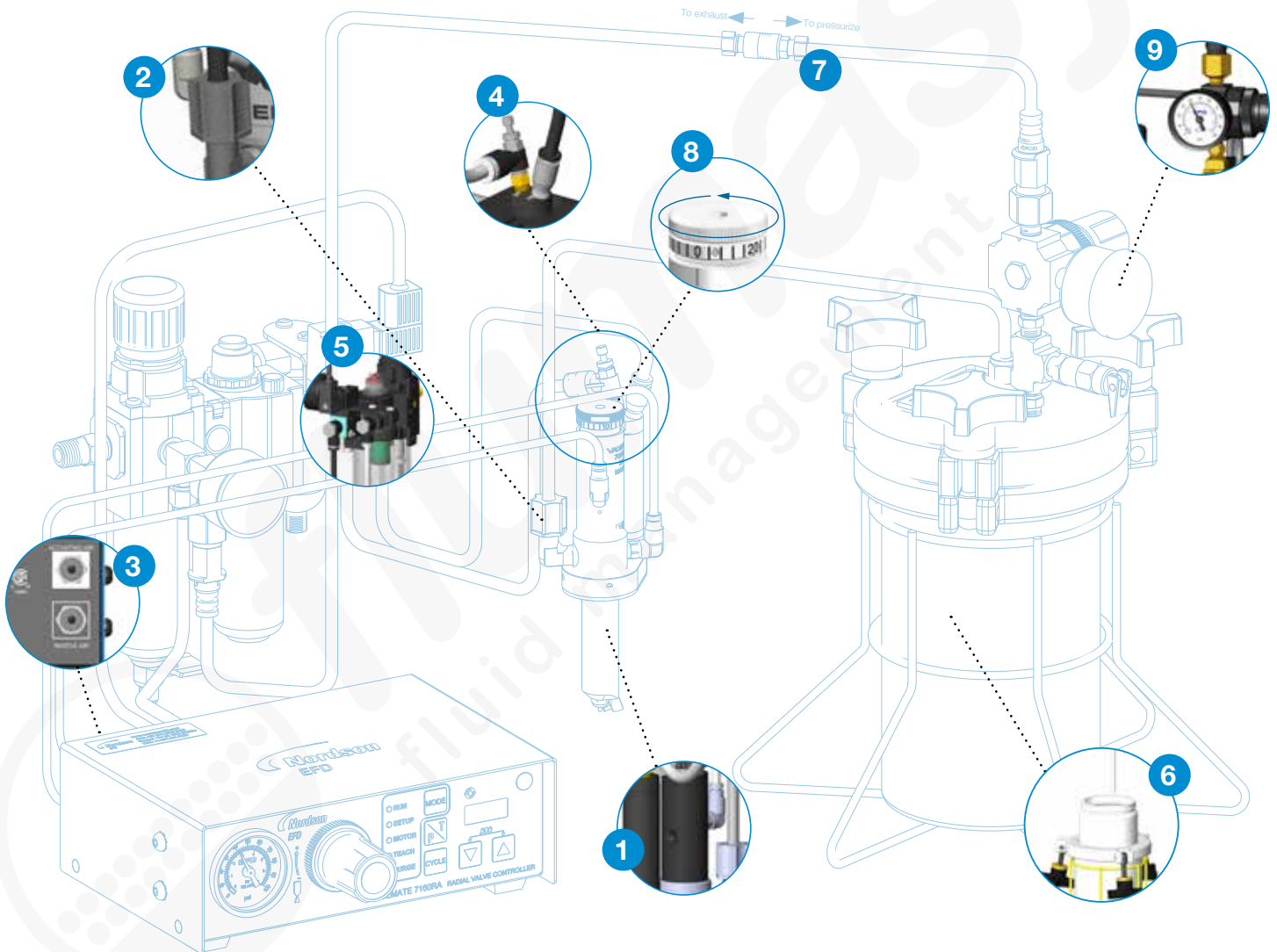

8. Set the needle stroke control at one turn open. This is a starting point. The final setting will be determined by the desired flow rate.
9. Set the reservoir pressure regulator according to fluid viscosity: low for thin fluids [1 to 3 psi (0.07 to 0.2 bar)] and higher for thick fluids.

How the Valve Operates

Input-air pressure at 4.8 bar (70 psi) acts on a piston ❶ that retracts the needle ❷ from its nozzle seat ❸, permitting fluid flow from the nozzle ❹. At the same time, nozzle air from the ValveMate 7160RA controller is turned on and flows from the rotor air tube ❺ across the fluid nozzle at a 70-degree angle.

This nozzle air creates a pressure drop around the nozzle, causing fluid to atomize into fine droplets and follow the direction of the nozzle air flow. The rotor, spinning at approximately 2500 rpm, causes the radial output to sweep around and evenly coat the inner circumference of the cylinder.

When the timed actuating air from the ValveMate 7160RA controller shuts off, the piston spring moves the needle onto the nozzle seat and shuts-off fluid flow. An adjustable nozzle air delay ensures that all fluid is atomized after the valve closes, eliminating post-deposit spatter.

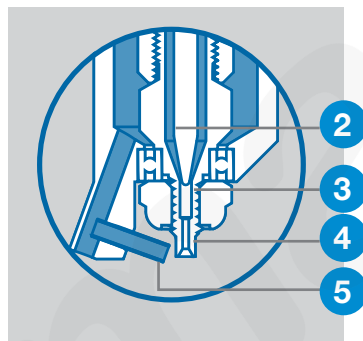

Open

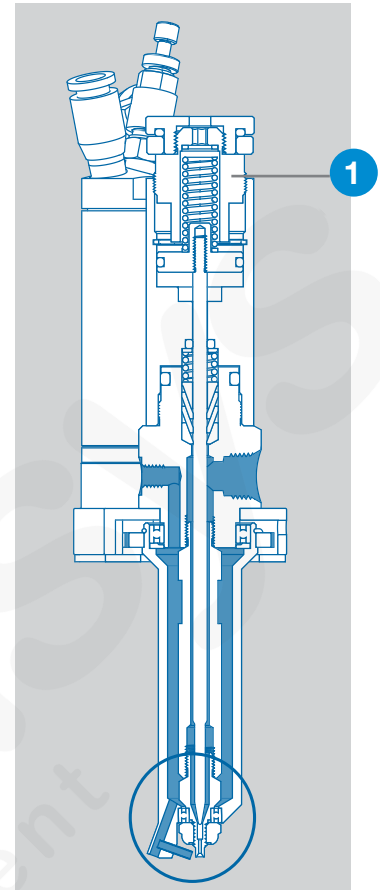

Closed

ValveMate Controller Concept

The ValveMate 7160RA radial system controller provides easy adjustment of valve output for maximum end-user convenience and efficiency. Valve open time is the primary control of deposit size. The 7160RA puts push-button adjustment of valve open-time where it needs to be—at the valve and radial spinner assembly.

The controller incorporates unique microprocessor circuitry to provide exact time control and to interact with the host computer.

An initial deposit size can be rapidly programmed by using the 7160RA TEACH mode. Refinements can be made by using the time setup controls.



Rear panel:

Air in
Power input
Actuating air
Nozzle air
I/O Interface
Foot pedal connector

Control panel:

Setup mode controls
Mode indicators
Time, time override
Cycle/purge control
Air in digital readout
Nozzle air gage and regulator

www.nordsonefd.com info@nordsonefd.com USA 800-556-3484 Europe +44 (0) 1582 666334 Asia +86 (21) 3866 9006



Specifications

Size: 74.5 mm length x 68.6 mm diameter (6.87 in. x 2.70 in.)

Weight: 408.2 g (14.4 oz)

Air consumption: <0.3 SCFM at 5.4 bar (80 psi)

Air cylinder body: Hard-coated aluminum

Fluid body: Hard-coated aluminum

Piston: Type 303 stainless steel

Piston return spring: Stainless steel

Needle and nozzle: Stainless steel

Rotor: Hard-coated aluminum

Fluid inlet hole: 1/8 NPT female

Air pressure required: 4.8 bar (70 psi)

Mounting: 1/4-28 UNF tapped hole

For consistent dispense valve operation and easy adjustment of valve output, Nordson EFD recommends using the ValveMate 7160RA controller on all automatic, semi-automatic and benchtop applications.

Contact the EFD Dispense Valve Systems Group for details.

Spray Coverage

782RA valve distance from nozzle center to inside diameter of cylinder wall

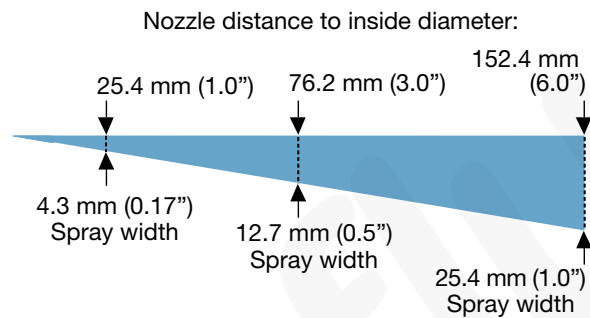

Spray coverage shown 1/2 actual size

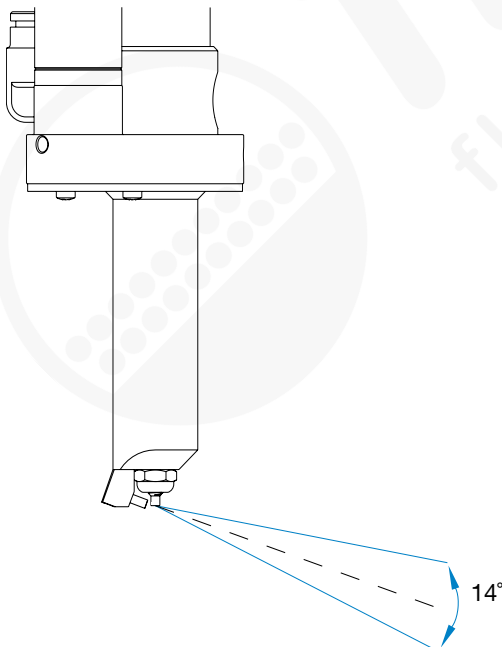

Nordson
EFD

 **flumasys**
fluid management
Flumasys s.r.o.
info@flumasys.com