

787MS-SS valve system produces spray patterns as small as 3.3 mm (0.130")

activators coatings inks liquid fluxes oils silicones solvents



The 787MS-SS Series is a precision spray valve that uses low volume low pressure (LVLP) technology to produce uniform spray patterns between 3.3 mm and 19 mm (0.130 and 0.75") in diameter.

Innovative design uses a small gauge 0.3 mm – 0.1 mm (0.013" – 0.004" ID) disposable dispensing tip in place of a standard spray nozzle. This concentrates the LVLP air used to atomize the coating into uniform spray patterns over 30% smaller than Nordson EFD's standard spray valve configuration. Between shots the valve needle seats in the hub of the dispensing tip, virtually eliminating dead fluid volume.

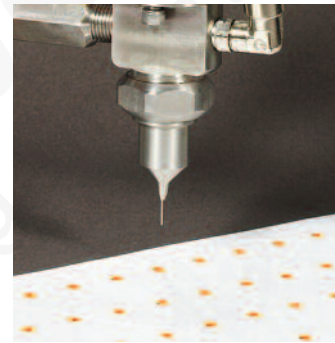

Features

- High transfer efficiency
- No overspray or mist
- Medium- to low-viscosity fluids
- Consistent spray patterns
- Cycle rate exceeds 400/minute
- Low maintenance design

Electronic pdf files of Nordson EFD manuals are also available at www.nordsonefd.com

Spray valve systems

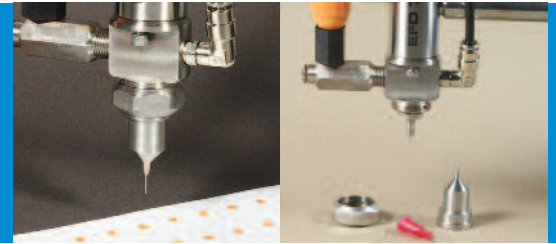

The complete system includes the 787MS-SS dispense valve, ValveMate 8040 controller, and the fluid reservoir.

Expert technical assistance and high quality standards ensure productive, trouble-free performance. Nordson EFD offers a full line of reliable dispensing systems to meet your specific application requirements.

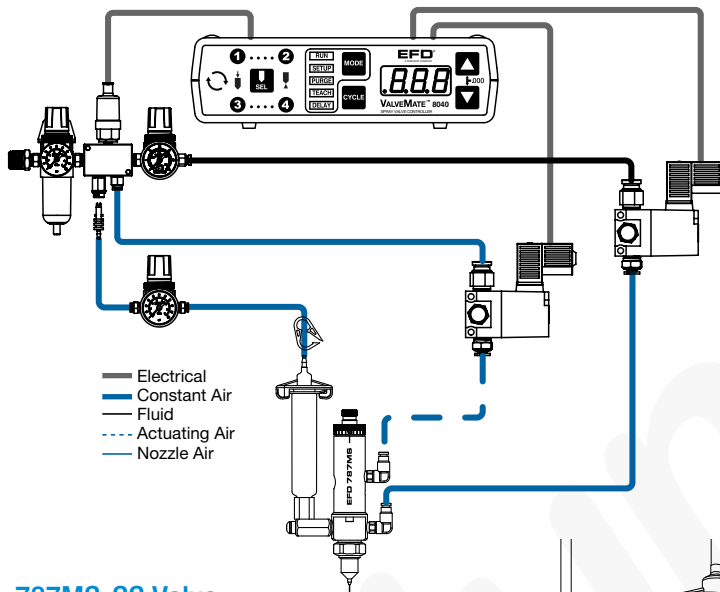

ValveMate 8040 Controller

The ValveMate controls valve open time and nozzle pressure. Its compact size allows the controller to be mounted near the valve for easy setup and spray adjustment.

- Multi-valve control- up to (2) spray valves
- Partner to Programmable Logic Controller (PLC)
- Easy control for consistent coverage
- Precise control of nozzle air pressure
- End-of-cycle air delay prevents valve from clogging
- End user convenience
- Maximum machine efficiency

Automation: XYZ & XYZR Robot Dispensing Systems

Nordson EFD offers a wide selection of XYZ and XYZR robot systems that are fully compatible with ValveMate valve controller systems. Consistent, accurate, repeatable and complex dispensing applications can be easily performed with EFD robots, with working envelopes that range from 200 x 200 x 50mm to 510 x 510 x 100mm. Scara robot systems are also available for larger, heavier products or inline dispensing applications.

Fluid Reservoirs

Nordson EFD reservoirs are supplied with precision, constant-bleed regulators to ensure consistent fluid pressure to the valve. Tank reservoirs are available in 1.0, 5.0 and 19.0 liter capacities. Cartridge sizes range from 2.5 to 32 ounces (75 cc to 950 cc).

787MS-SS Valve

The 787MS-SS is a precision low volume low pressure (LVLP) spray valve that uses 23-33 gauge (0.013"-0.004" ID) dispensing tips to produce uniform spray patterns as small as 3.3 mm (0.130") wide.

Specifications:

Size: 131.6 mm length x 26.9 mm diameter (5.18" x 1.06")

Weight: 336 grams (11.8 oz)

Fluid body: Type 303 stainless steel

Air cylinder body: Type 303 stainless steel

Piston: Type 303 stainless steel

Needle: Type 303 stainless steel

Fluid inlet thread: 1/8 NPT female

Air cap: Type 303 stainless steel

Free flow orifice: 33 ga (.004, 0.10mm) to 23 ga (.013, 0.33 mm)

Needle packagings: PTFE

Mounting: ¼-28 UNF tapped hole

Maximum fluid pressure: 100 psi

Maximum operating temperature: 102°C (215°F)

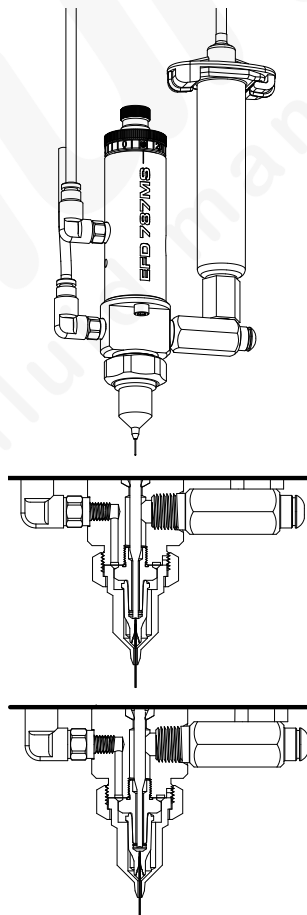

Flumasys s.r.o.
info@flumasys.com