

xQR41 Series MicroDot Needle Valve

Operating Manual



Electronic pdf files of Nordson EFD manuals are also available at www.nordsonefd.com



You have selected a reliable, high-quality dispensing system from Nordson EFD, the world leader in fluid dispensing. The xQR41 Series MicroDot™ needle valve was designed specifically for industrial dispensing and will provide you with years of trouble-free, productive service.

This manual will help you maximize the usefulness of your xQR41 MicroDot needle valve.

Please spend a few minutes to become familiar with the controls and features. Follow our recommended testing procedures. Review the helpful information we have included, which is based on more than 50 years of industrial dispensing experience.

Most questions you will have are answered in this manual. However, if you need assistance, please do not hesitate to contact EFD or your authorized EFD distributor. Detailed contact information is provided on the last page of this document.

The Nordson EFD Pledge

Thank You!

You have just purchased the world's finest precision dispensing equipment.

I want you to know that all of us at Nordson EFD value your business and will do everything in our power to make you a satisfied customer.

If at any time you are not fully satisfied with our equipment or the support provided by your Nordson EFD Product Application Specialist, please contact me personally at 800.556.3484 (US), 401.431.7000 (outside US), or Srini.Subramanian@nordsonefd.com.

I guarantee that we will resolve any problems to your satisfaction.

Thanks again for choosing Nordson EFD.

Srini Subramanian

Srini Subramanian, General Manager



Contents

Contents	3
Introduction	4
xQR41 Series Valve Options.....	4
BackPack Valve Actuator.....	4
Mounting Block Actuating Air Inlet.....	4
90° Low-Profile Air Inlet Push-In Fitting	4
PEEK Wetted Parts	4
How the xQR41 Valve Operates	5
How the QR Clasp Works.....	5
How to Control the xQR41 Valve.....	6
Specifications.....	7
xQR41 Series Valve	7
BackPack Valve Actuator	7
Mounting Block Actuating Air Inlet	7
Operating Features.....	8
Installation	9
Mounting the Valve on the Dispensing Equipment.....	9
Installing a 90° Fluid Inlet Fitting.....	9
Making the System Connections.....	10
ValveMate 8000 System with an xQR41 Valve and BackPack Valve Actuator	10
ValveMate 8000 System with an xQR41 Valve and Mounting Block.....	11
ValveMate 7100 System with an xQR41 Valve	12
Dispensing Tip Change and Valve Stroke Calibration.....	13
Fluid Body Change.....	14
Service.....	15
Cleaning the Valve	15
Replacing the Piston and Needle Assembly or the Piston O-Ring.....	16
Replacing the Bullet Solenoid on the BackPack Valve Actuator.....	17
Part Numbers	18
Replacement Parts.....	18
Valve Components	18
BackPack Valve Actuator	19
Mounting Brackets	19
Troubleshooting	20

Introduction

The xQR41 Series MicroDot needle valve is a pneumatically operated, adjustable, modular valve designed to apply precise micro-deposits of low- to high-viscosity fluids onto a substrate. The xQR41 valve is ideal for automated assembly processes that require small dispensing tips (from 22 to 33 gauge). The valve provides exceptional control as well as the absolute minimum of dead fluid volume, resulting in accurate, precise, and repeatable deposits.

The fluid body offers 360° rotational movement, allowing the fluid inlet to be positioned in the best orientation for fluid feed to the valve.

The xQR41 valve's unique quick-release (QR) clasp secures the fluid body to the air cylinder body and can be removed in seconds for fast change-out and easy cleaning and maintenance of the valve's wetted parts.

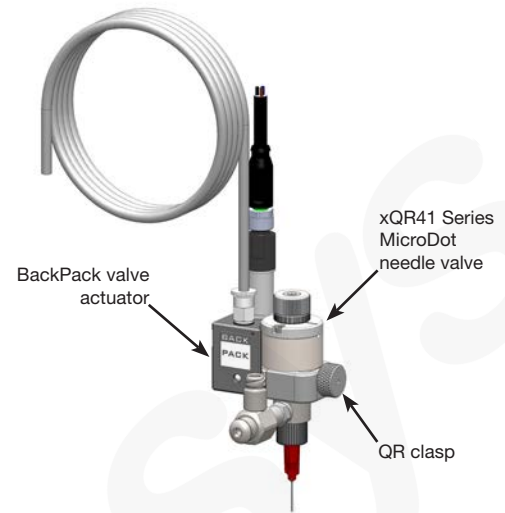

xQR41 Series Valve Options

The modular design of the xQR41 allows a variety of setup configurations to provide the best solution for fluid dispensing and production line installation.

BackPack Valve Actuator

The optional Backpack™ valve actuator can be mounted on the xQR41 valve's actuating air cylinder body to (1) provide faster valve response time and (2) to reduce the possibility of variations in deposit size due to a fluctuating plant air supply or different air line lengths.

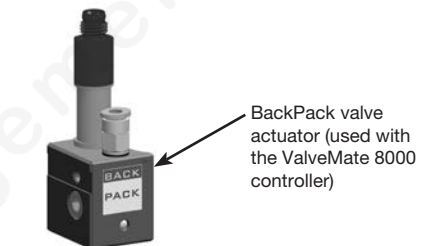

Mounting Block Actuating Air Inlet

The optional mounting block is a convenient push-in actuation air inlet fitting and flat mounting surface for easy installation onto fixture plates.

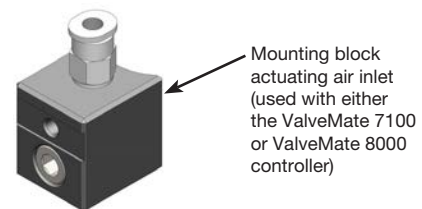

90° Low-Profile Air Inlet Push-In Fitting

The optional 90° low-profile air inlet fitting is a convenient push-in fitting actuation air inlet connection for applications requiring lighter weight and smaller footprint installations.

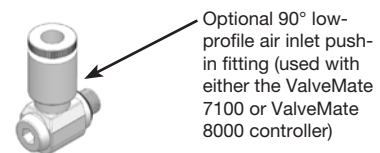

PEEK Wetted Parts

PEEK* wetted parts are available as an option to add to an existing valve or as a separate valve model. PEEK wetted parts are designed to resist curing from reactive adhesives, such as anaerobics. PEEK valve models include a PEEK fluid body and a PEEK needle-and-piston assembly (bullet end) that provide a barrier between adhesives and the wetted parts.



*Polyetheretherketone

How the xQR41 Valve Operates

Input air pressure at 4.8 bar (70 psi) retracts the piston and needle from the needle seat in the dispensing tip, permitting fluid flow through the dispensing tip. Once the cycle is complete, air pressure is exhausted, causing the piston spring to return the needle back to its position in the dispensing tip, stopping fluid flow. When the dispensing tip is removed, the needle seats into a secondary seat, stopping fluid flow during tip replacement.

The amount of fluid dispensed will depend on the time the valve is open, fluid reservoir pressure, dispensing tip size, needle stroke, and fluid viscosity.

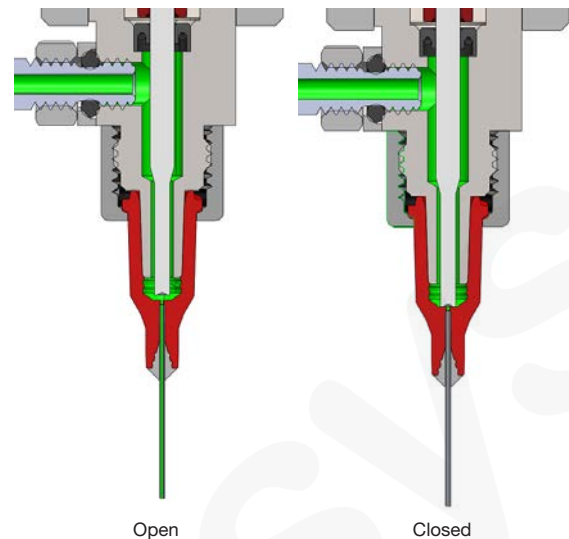

How the QR Clasp Works

The QR clasp slides into grooves on the body of the fluid valve to wedge the fluid body against the air cylinder body. A thumbscrew secures the entire valve assembly to prevent movement during cycling. The thumbscrew also acts like a jack screw to ease QR clasp removal.

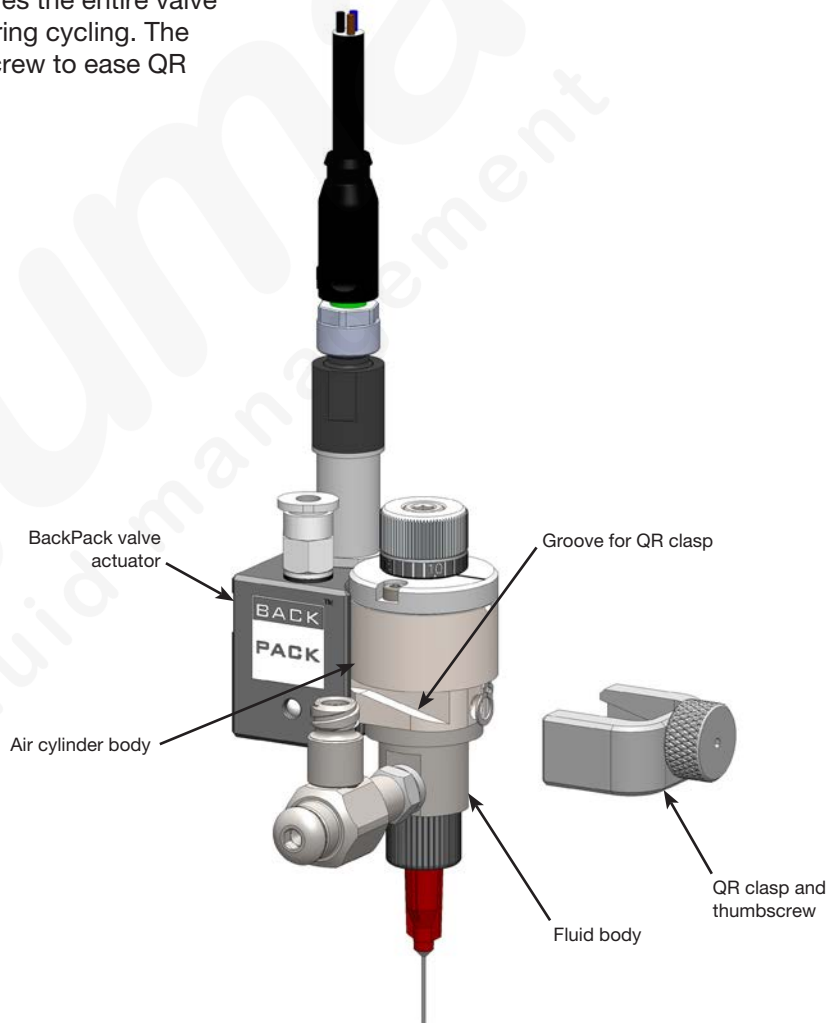

How to Control the xQR41 Valve

Two controllers are recommended for use with the xQR41 Series Microdot needle valves: the ValveMate™ 8000 and the ValveMate 7100.

For multi-valve installations using the Backpack valve actuator, mounting block, or 90° low-profile air inlet fitting, use the ValveMate 8000 controller to provide easy adjustment of valve output for maximum end-user convenience and efficiency. Valve open time is the primary control of deposit size. The ValveMate 8000 controller puts push-button adjustment of valve open time where it needs to be—at the valve.

The ValveMate 8000 features micro-processor circuitry for extremely precise control of deposit size. Feed lines can be purged, initial deposit sizes set, and adjustments made quickly and easily at the dispensing station, without stopping the production line.

For single valve installations using the mounting block or 90° low-profile air inlet, use the ValveMate 7100 controller. Incorporating programmable dispense time, digital time readout, keypad programming for easy user interface, and input/output communication with host machine PLCs, the ValveMate 7100 has been designed with the machine builder and operator in mind. The objectives are to bring dispensing control close to the point of application and to provide the features necessary to make setup and operation as easy and precise as possible.

NOTE: The ValveMate 7100 controller cannot be used with the xQR41 Backpack valve actuator.



Specifications

NOTE: Specifications and technical details are subject to change without prior notification.

xQR41 Series Valve

Item	Specification								
Size	66.0 mm length x 23.7 mm diameter (2.60 x 0.93")								
Weight	<table border="0"> <tr> <td>Valve with standard fluid body</td> <td>Valve with PEEK wetted parts</td> </tr> <tr> <td>Valve only: 141.4 g (5.0 oz)</td> <td>Valve only: 115.0 g (4.1 oz)</td> </tr> <tr> <td>With Backpack actuator: 196.1 g (6.9 oz)</td> <td>With Backpack actuator: 170.0 g (6.0 oz)</td> </tr> <tr> <td>With mounting block: 166.4 g (5.9 oz)</td> <td>With mounting block: 140.0 g (4.9 oz)</td> </tr> </table>	Valve with standard fluid body	Valve with PEEK wetted parts	Valve only: 141.4 g (5.0 oz)	Valve only: 115.0 g (4.1 oz)	With Backpack actuator: 196.1 g (6.9 oz)	With Backpack actuator: 170.0 g (6.0 oz)	With mounting block: 166.4 g (5.9 oz)	With mounting block: 140.0 g (4.9 oz)
Valve with standard fluid body	Valve with PEEK wetted parts								
Valve only: 141.4 g (5.0 oz)	Valve only: 115.0 g (4.1 oz)								
With Backpack actuator: 196.1 g (6.9 oz)	With Backpack actuator: 170.0 g (6.0 oz)								
With mounting block: 166.4 g (5.9 oz)	With mounting block: 140.0 g (4.9 oz)								
Actuating air pressure required	4.8–6.2 bar (70–90 psi)								
Maximum fluid pressure	7.0 bar (100 psi)								
Fluid inlet	M5								
Fluid outlet	Luer taper with retaining nut								
Mounting	M4 (BackPack valve actuator or mounting block)								
Cycle rate	Exceeds 400 per minute								
Air cylinder body	303 stainless steel								
Fluid body	303 stainless steel or PEEK								
Piston	303 stainless steel								
Needle	303 stainless steel or PEEK								
Tip retaining nut	Hard-coated aluminum								
SafetyLok™ collar	Hard-coated anodized aluminum								
Maximum operating temperature	80° C (176° F)								
US Patent No. 9,816,849 for QR clasp									

All stainless steel valve parts are passivated.

BackPack Valve Actuator

Item	Specification		
Size	26.2w x 26.7H x 18.4D mm (1.03w x 1.05H x 0.72D")		
Weight	<table border="0"> <tr> <td>Valve actuator only: 53.8 g (1.90 oz)</td> </tr> <tr> <td>Installed on xQR41 valve: 196.1 g (6.90 oz)</td> </tr> </table>	Valve actuator only: 53.8 g (1.90 oz)	Installed on xQR41 valve: 196.1 g (6.90 oz)
Valve actuator only: 53.8 g (1.90 oz)			
Installed on xQR41 valve: 196.1 g (6.90 oz)			
Actuating air pressure required	4.8–6.2 bar (70–90 psi)		
Electrical input	24 VDC, 4 W		
Minimum actuation time	5 ms		
Maximum actuation time	Continuous ON		
Operating frequency	60–80Hz		
Housing	Anodized aluminum		
Mounting bolt	303 stainless steel		

All stainless steel valve parts are passivated.

Mounting Block Actuating Air Inlet

Item	Specification		
Size	18.4w x 21.6H x 21.4D mm (0.72w x 0.85H x 0.84D")		
Weight	<table border="0"> <tr> <td>Mounting block only: 25.0 g (0.90 oz)</td> </tr> <tr> <td>Installed on xQR41 valve: 166.4 g (5.9 oz)</td> </tr> </table>	Mounting block only: 25.0 g (0.90 oz)	Installed on xQR41 valve: 166.4 g (5.9 oz)
Mounting block only: 25.0 g (0.90 oz)			
Installed on xQR41 valve: 166.4 g (5.9 oz)			
Housing	Anodized aluminum		
Mounting bolt	303 stainless steel		

All stainless steel valve parts are passivated.

Operating Features

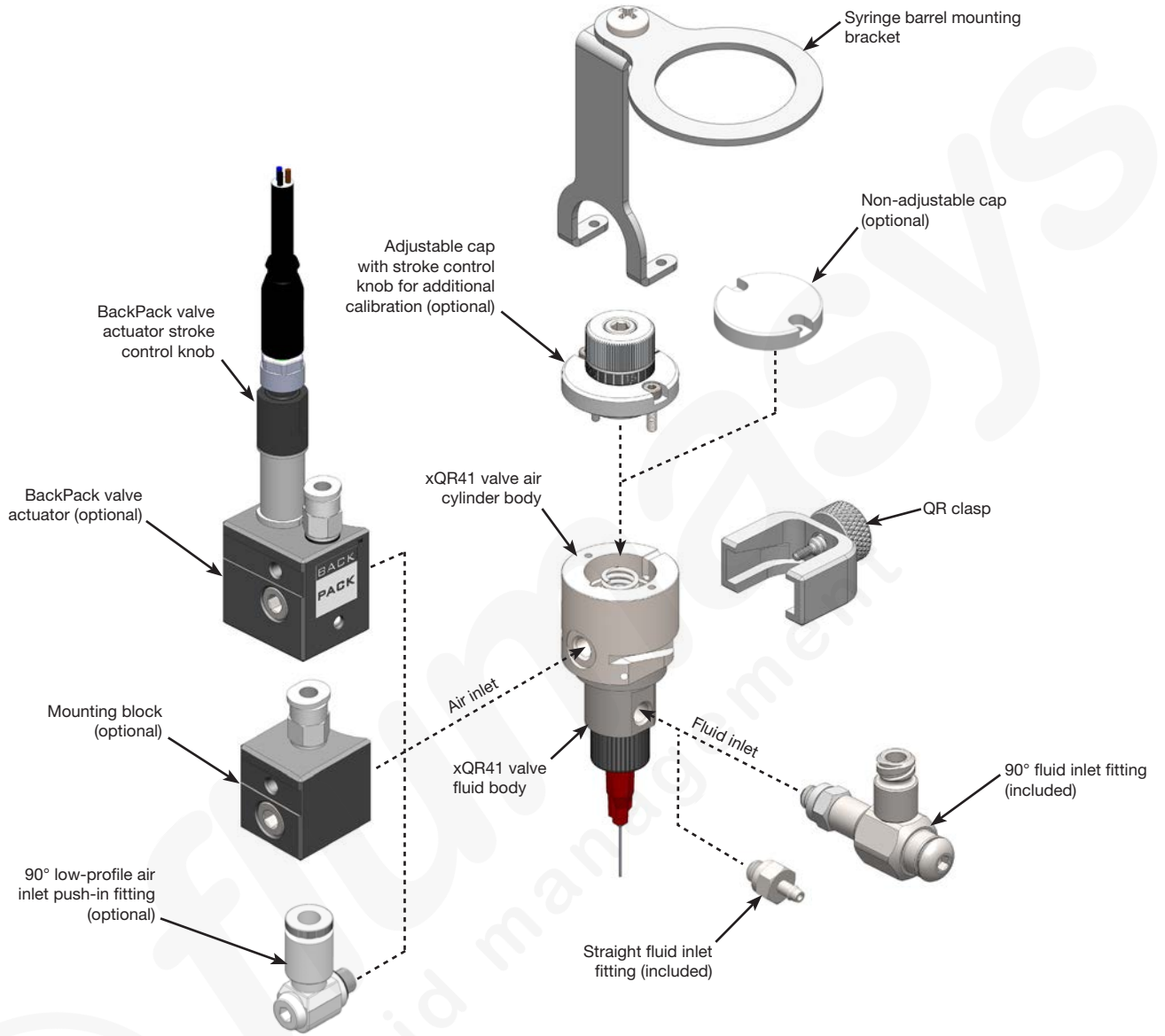

Installation

NOTE: Prior to installing the valve, read the associated reservoir and valve controller operating manuals to become familiar with the operation of all components of the dispensing system.

Mounting the Valve on the Dispensing Equipment

1. Secure the xQR41 valve to the BackPack valve actuator or to the mounting block, as applicable.
2. (Optional) Secure the valve and BackPack / mounting block assembly to the mounting bracket. There are multiple mounting holes to allow for adjustment.
3. Install the complete assembly on the dispensing equipment.

CAUTION

Do not over-tighten the QR clasp thumb screw. Doing so can break the screw.

4. Orient the fluid body and install the QR clasp as follows:
 - a. Partially thread the QR clasp thumbscrew into the air cylinder body.
 - b. When the thumbscrew is engaged, rotate the fluid body to the required alignment based on the use of a 90° fluid inlet fitting.
 - c. Finger-tighten the thumbscrew to fully secure fluid body to the air cylinder.

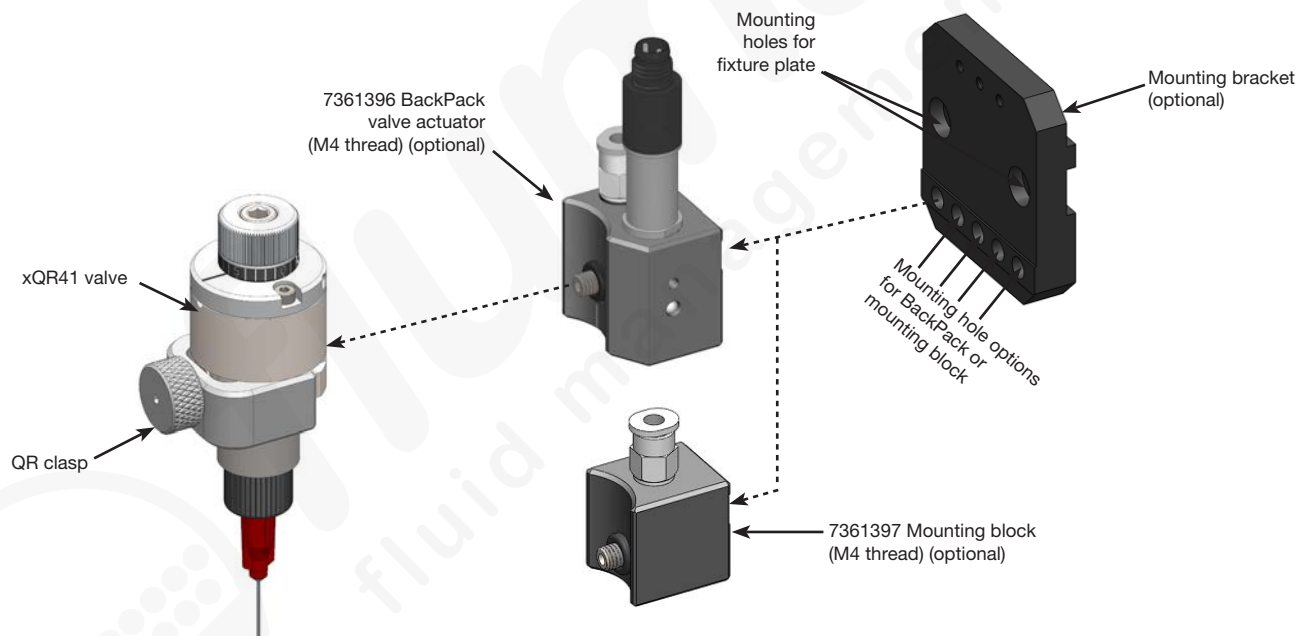

Installing a 90° Fluid Inlet Fitting

1. Thread the fitting nut fully onto the 90° fluid inlet fitting (towards the Luer fitting).
2. Fully thread the 90° fluid inlet fitting assembly into the valve fluid body, then unthread the assembly until the Luer fitting is at the desired orientation.

NOTE: Do not unthread the 90° fluid inlet fitting more than one (1) turn.

3. Use an 8 mm wrench to tighten the fitting nut against the fluid body.

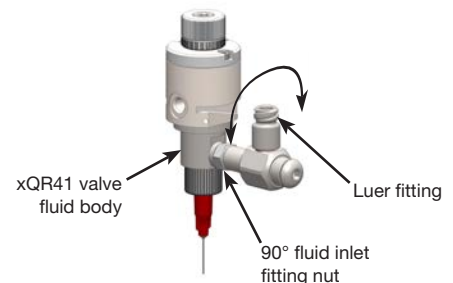

Making the System Connections

For complete installation, set up, and testing instructions, refer to the controller operating manual.

ValveMate 8000 System with an xQR41 Valve and Backpack Valve Actuator

This illustration shows a complete installation using the ValveMate 8000 controller and the Backpack valve actuator option.

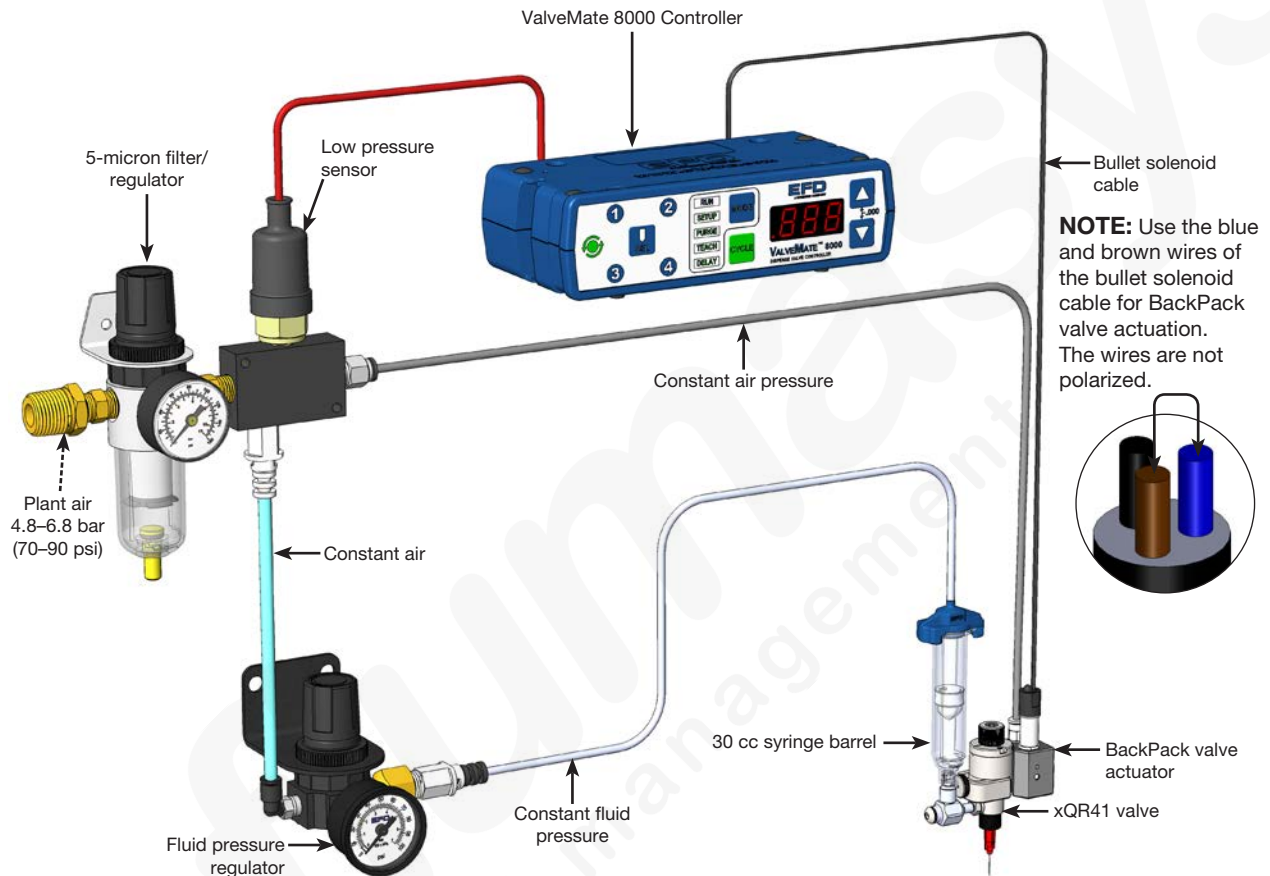

Making the System Connections (continued)

For complete installation, set up, and testing instructions, refer to the controller operating manual.

ValveMate 8000 System with an xQR41 Valve and Mounting Block

This illustration shows a complete installation using the ValveMate 8000 controller and the mounting block option.

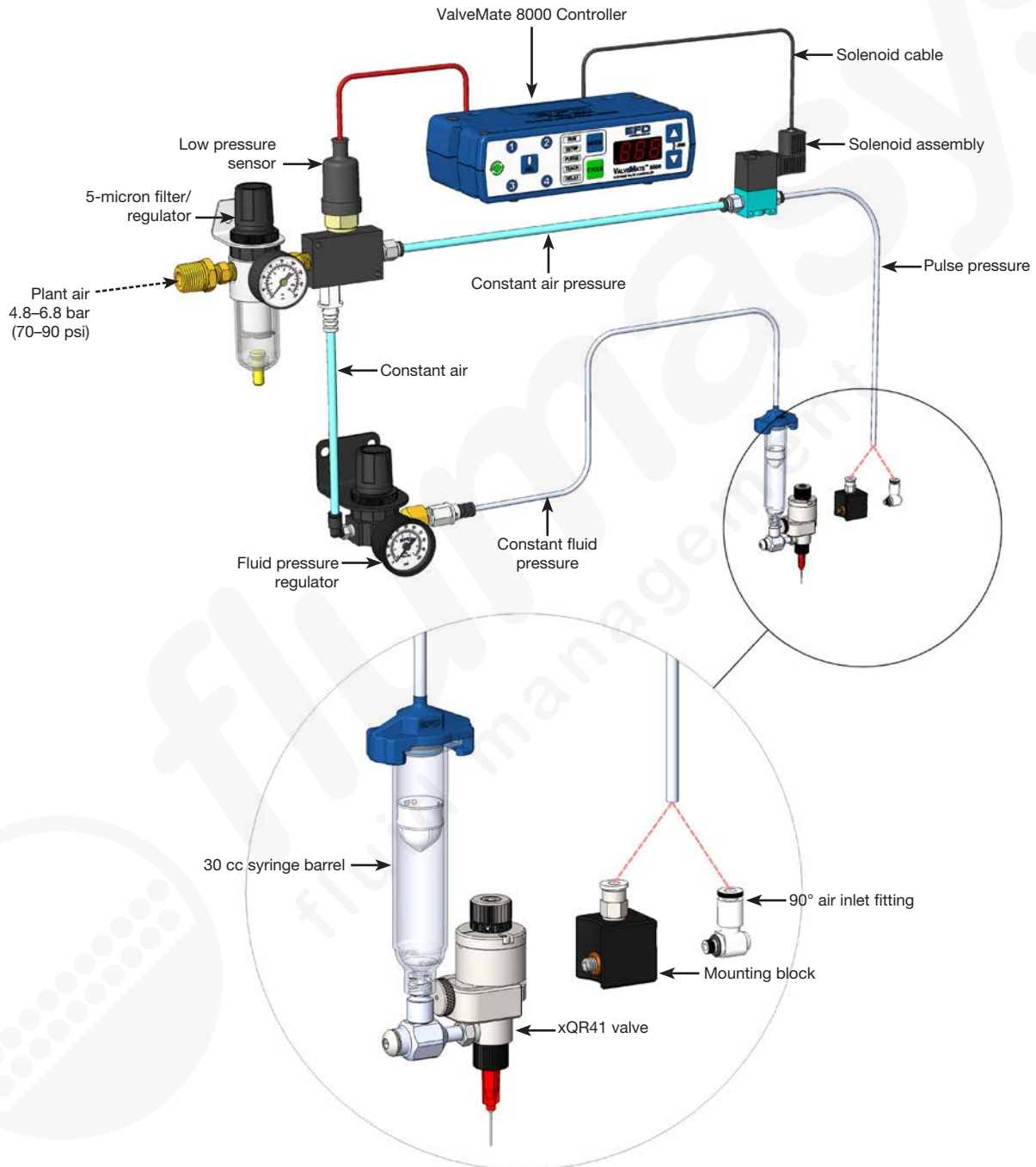

Making the System Connections (continued)

For complete installation, set up, and testing instructions, refer to the controller operating manual.

ValveMate 7100 System with an xQR41 Valve

This illustration shows a complete installation using the ValveMate 7100 controller.

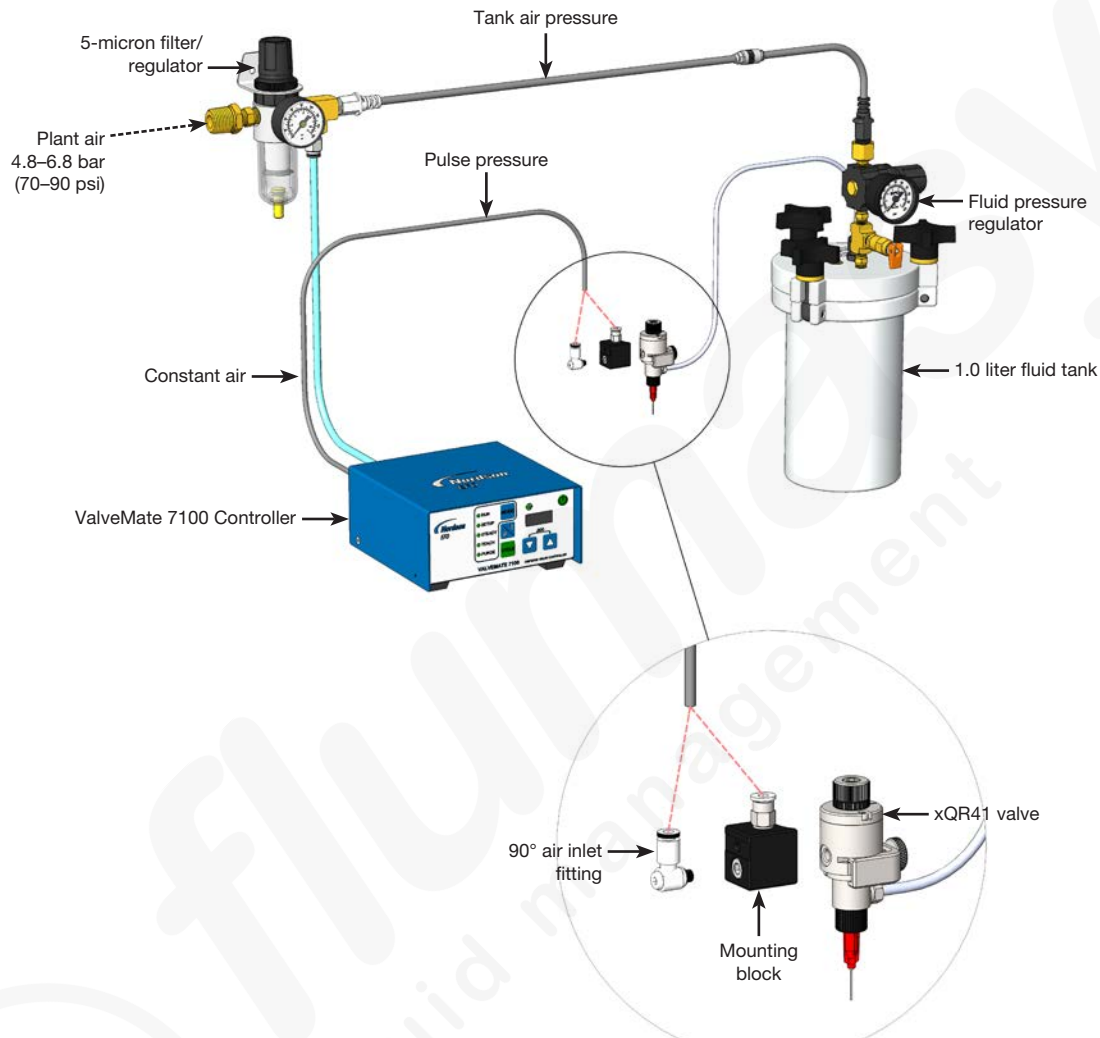

⚠ CAUTION

Always de-pressurize the fluid reservoir before opening it. To do this, slide the shutoff valve on the air line away from the reservoir. Before opening the reservoir, check the pressure gauge to verify that pressure is zero (0). If using an EFD tank, also open the pressure relief valve.

On all EFD cartridge reservoirs, the unique threaded design provides fail-safe air pressure release during cap removal.

Dispensing Tip Change and Valve Stroke Calibration

Your xQR41 valve will have either a non-adjustable cap or an adjustable cap with a stroke control knob. On valves with a stroke control knob, the stroke control reference ring is factory calibrated to the zero (0) position. Slight internal variations in dispensing tips may require the stroke control to be recalibrated when a dispensing tip is changed.

⚠ CAUTION

Before any component change or service activity, relieve air pressure from the fluid reservoirs.

To change the dispensing tip (valves with a non-adjustable cap)

1. Remove the retaining nut and then remove the dispensing tip.
2. Install the new dispensing tip and secure it with the retaining nut. Ensure that the retaining nut is fully tightened.

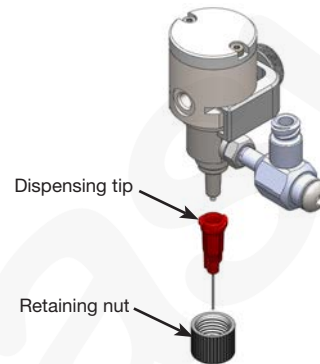

To change the dispensing tip and calibrate the stroke control knob (valves with a stroke control knob)

3. Make a note of the current stroke number setting.
4. Turn the stroke control knob counterclockwise one-half turn (or to fully open).
5. Remove the retaining nut and then remove the dispensing tip.
6. Install the new dispensing tip and secure it with the retaining nut. Ensure that the retaining nut is fully tightened.

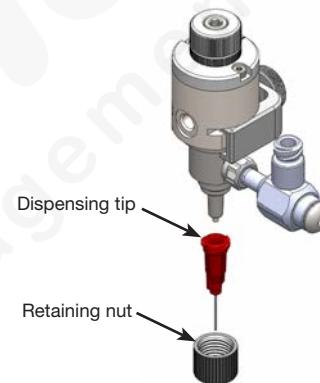

⚠ CAUTION

Do not over-tighten the stroke control knob. Tightening the knob past 2.6 N•m (20 in.-lb) of torque can damage the knob.

7. Turn the stroke control knob clockwise until it stops (at the internal piston).
8. If necessary, use an 0.035" hex wrench to re-zero the reference ring by aligning the zero mark with the reference mark on the air cylinder body.
9. Tighten the set screw to lock the stroke reference ring in position.
10. Reset the stroke number setting to the position noted in step 1.

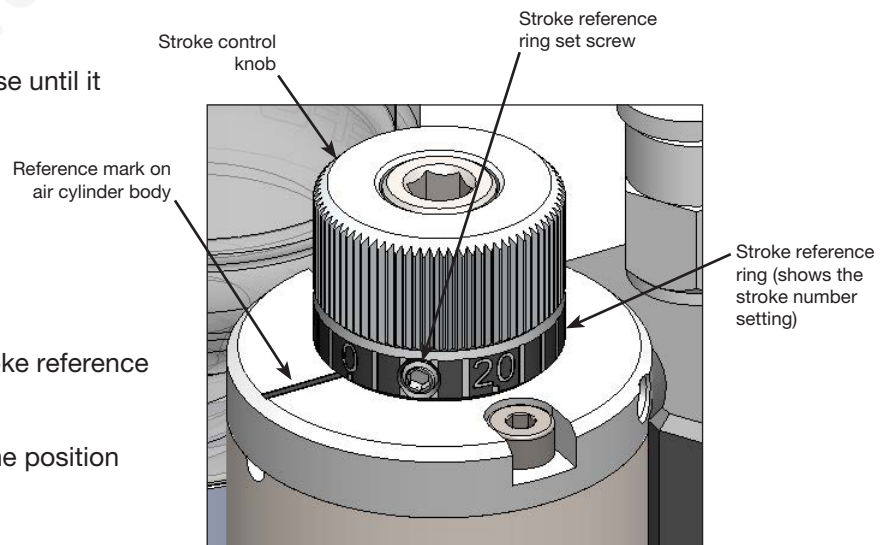

Fluid Body Change

You can quickly remove the fluid body of the xQR41 valve and install a replacement fluid body, thus greatly minimizing downtime. The removed fluid body can be serviced and ready for use for the next required fluid body change-out.

⚠ CAUTION

Before any component change or service activity, relieve air pressure from the fluid reservoirs.

1. Remove the syringe barrel from the 90° fluid inlet fitting.
2. **On adjustable cap valves only:**
 - a. Make a note of the current stroke number setting.
 - b. Turn the stroke control knob counterclockwise one-half turn (or to fully open).
3. Turn the QR clasp thumbscrew counterclockwise to disengage the clasp.
4. Carefully move the fluid body downward until it clears the air cylinder / needle assembly.

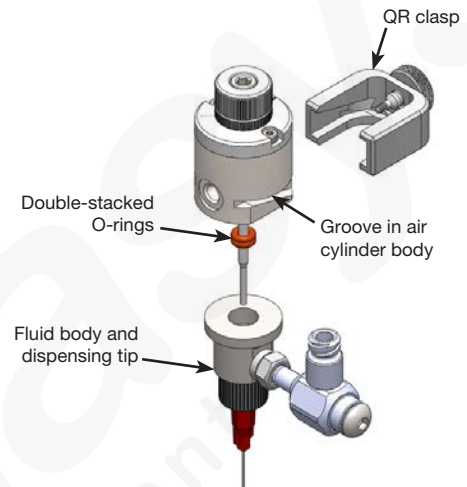

Fluid body change of a valve with double-stacked O-rings (valve with adjustable cap shown)

⚠ CAUTION

Do not wipe the needle with an abrasive material, specifically in chemically sensitive applications. Doing so can damage the needle.

5. Remove the double-stacked O-rings or spring-energized seal from either the needle assembly or the fluid body cavity. Wipe the needle clean of any remaining fluid.
 6. Apply a lubricant compatible with the dispensing fluid to new double-stacked O-rings (if applicable) and install the new double-stacked O-rings or a new spring-energized seal on the needle.
- NOTE:** If a spring-energized seal is used, install the seal with the spring facing the fluid flow.
7. Use one hand to position a replacement fluid body on the air cylinder / needle assembly and then slide the QR clasp into the grooves on the cylinder body.

Correct orientation of a spring-energized seal

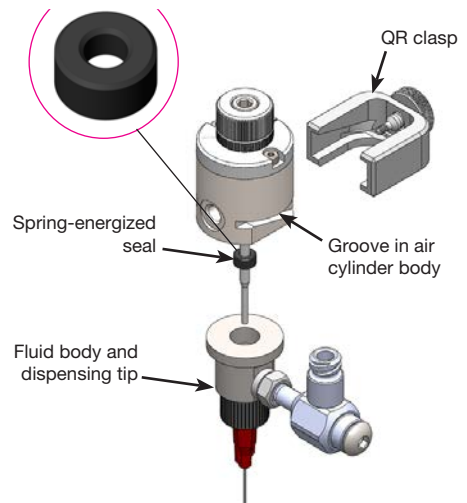

Fluid body change of a valve with a spring-energized seal (valve with adjustable cap shown)

⚠ CAUTION

Do not over-tighten the QR clasp thumb screw. Doing so can break the screw.

8. Fully install the QR clasp as follows:
 - a. Partially thread the QR clasp thumbscrew into the air cylinder body.
 - b. When the thumbscrew is engaged, rotate the fluid body to the required alignment.
 - c. Finger-tighten the thumbscrew to fully secure fluid body to the air cylinder.
9. **On adjustable cap valves only:**

Follow steps 5–8 under “To change the dispensing tip and calibrate the stroke control knob (valves with a stroke control knob)” on page 13 to calibrate the stroke control knob.

Service

Perform these service procedures as needed for the best valve operation.

⚠ CAUTION

Before any component change or service activity, relieve air pressure from the fluid reservoirs.

⚠ CAUTION

To prevent damage, begin disassembly of the valve at the fluid outlet end.

Cleaning the Valve

Follow this procedure to thoroughly clean the fluid body and to replace the fluid body O-ring seal.

1. Turn the QR clasp thumbscrew counterclockwise to disengage the clasp.
2. Carefully move the fluid body downward until it clears the air cylinder / needle assembly.
3. If the fluid body O-ring seal (not shown) remains on the piston needle, gently slide it off the needle.

⚠ CAUTION

Do not wipe the needle with an abrasive material, specifically in chemically sensitive applications. Doing so can damage the needle.

4. Clean the needle with a cloth dampened in solvent.
5. Install a replacement double-stacked O-ring set or spring-energized seal on the needle.

NOTE: Lubricate double-stacked O-rings before installing. Use the supplied fluorocarbon grease only if the assembly fluid being dispensed is compatible with it.

NOTE: If a spring-energized seal is used, install the seal with the spring facing the fluid flow.

6. Use one hand to position the fluid body on the air cylinder / needle assembly and then slide the QR clasp into the grooves on the air cylinder body.

⚠ CAUTION

Do not over-tighten the QR clasp thumb screw. Doing so can break the screw.

7. Fully install the QR clasp as follows:
 - a. Partially thread the QR clasp thumbscrew into the air cylinder body.
 - b. When the thumbscrew is engaged, rotate the fluid body to the required alignment.
 - c. Finger-tighten the thumbscrew to fully secure fluid body to the air cylinder.

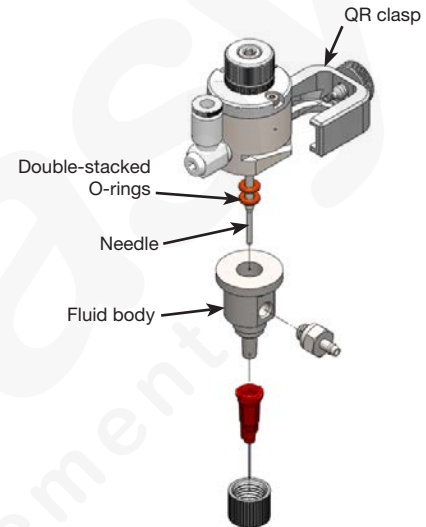

Cleaning a valve with double-stacked O-rings (valve with adjustable cap shown)

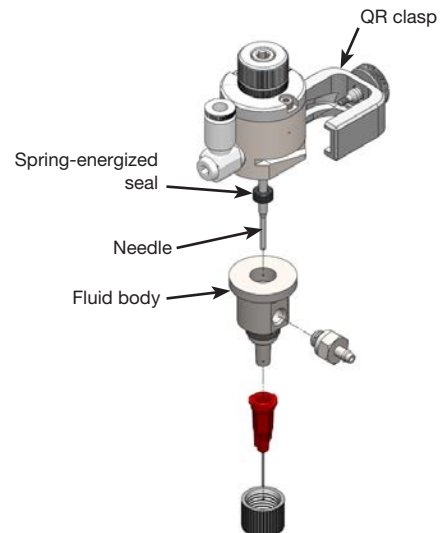

Cleaning a valve with a spring-energized seal (valve with adjustable cap shown)

Service (continued)

⚠ CAUTION

Before any component change or service activity, relieve air pressure from the fluid reservoirs.

Replacing the Piston and Needle Assembly or the Piston O-Ring

Follow this procedure to clean the air cylinder body and replace the piston O-ring.

1. **On adjustable cap valves only:**
 - a. Make a note of the current stroke setting number.
 - b. Turn the stroke control knob counterclockwise one-half turn (or to fully open).
2. Remove the cap (adjustable or non-adjustable).
3. Remove the piston return spring.
4. Using small pliers, grasp the spring pilot of the piston and needle assembly and then pull the assembly out of the air cylinder body.

NOTE: The piston and needle assembly is one unit and cannot be disassembled.
5. Remove the piston O-ring from the piston and needle assembly.
6. Clean the inside wall of the air cylinder body.
7. Lubricate the piston O-ring with Nye Lubricant #865 gel (P/N 7014917, included in the General Maintenance Kit) and reinstall the O-ring.
8. Reassemble the valve in the reverse order of disassembly, ensuring that the U-cup seal is in place.
9. **On adjustable cap valves only:**

Follow steps 5–8 under “To change the dispensing tip and calibrate the stroke control knob (valves with a stroke control knob)” on page 13 to calibrate the stroke control knob.

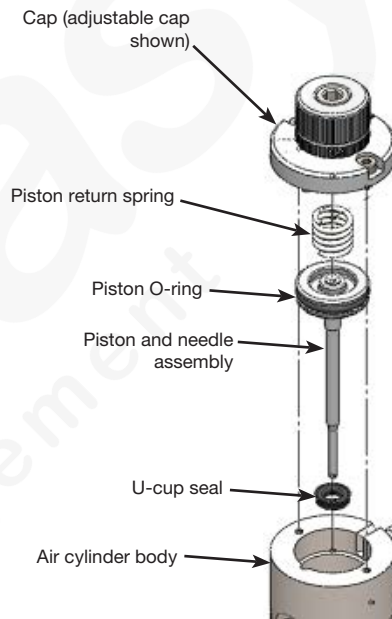

Service (continued)

CAUTION

Do not fully remove the mounting screw from the valve actuator housing. Be careful not to lose the BackPack mounting O-ring that is located between the BackPack and the xQR41 air cylinder body.

Replacing the Bullet Solenoid on the BackPack Valve Actuator

1. Loosen the housing / mounting bolt to release the BackPack valve actuator from the xQR41 valve air cylinder body.
2. Remove the spiral wrap (if used) around the BackPack valve actuator wires and air hose.
3. Disconnect the air line.
4. Unthread the cable connector from the bullet solenoid (cable not shown).
5. Engage the wrench flats on the bullet solenoid and rotate it counterclockwise. When the bullet solenoid is loose, pull up on the solenoid to release it.
6. Install a replacement bullet solenoid by rotating the solenoid clockwise until it is fully tightened.
7. Tighten the housing / mounting bolt and reconnect bullet solenoid cable connector and air line.

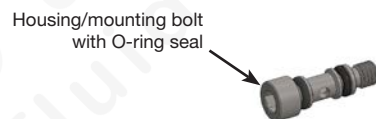

Part Numbers

Standard xQR41	PEEK* xQR41	Description
7360817	7361761	xQR41 valve with BackPack and stroke control knob
7360819	7361762	xQR41 valve with BackPack and non-adjusting cap
7360824	7361763	xQR41 valve with mounting block and stroke control knob
7360825	7361764	xQR41 valve with mounting block and non-adjusting cap
7360821	n/a	xQR41 valve with BackPack, stroke control knob, and bullet end needle**
7360823	n/a	xQR41 valve with mounting block, stroke control knob, and bullet end needle**

*xQR41 valves with PEEK wetted parts resist curing from reactive materials such as anaerobics.

**Use bullet end needle with smaller diameter 30 and 32/33 ga tips for more consistent microdot dispensing.

Replacement Parts

Valve Components

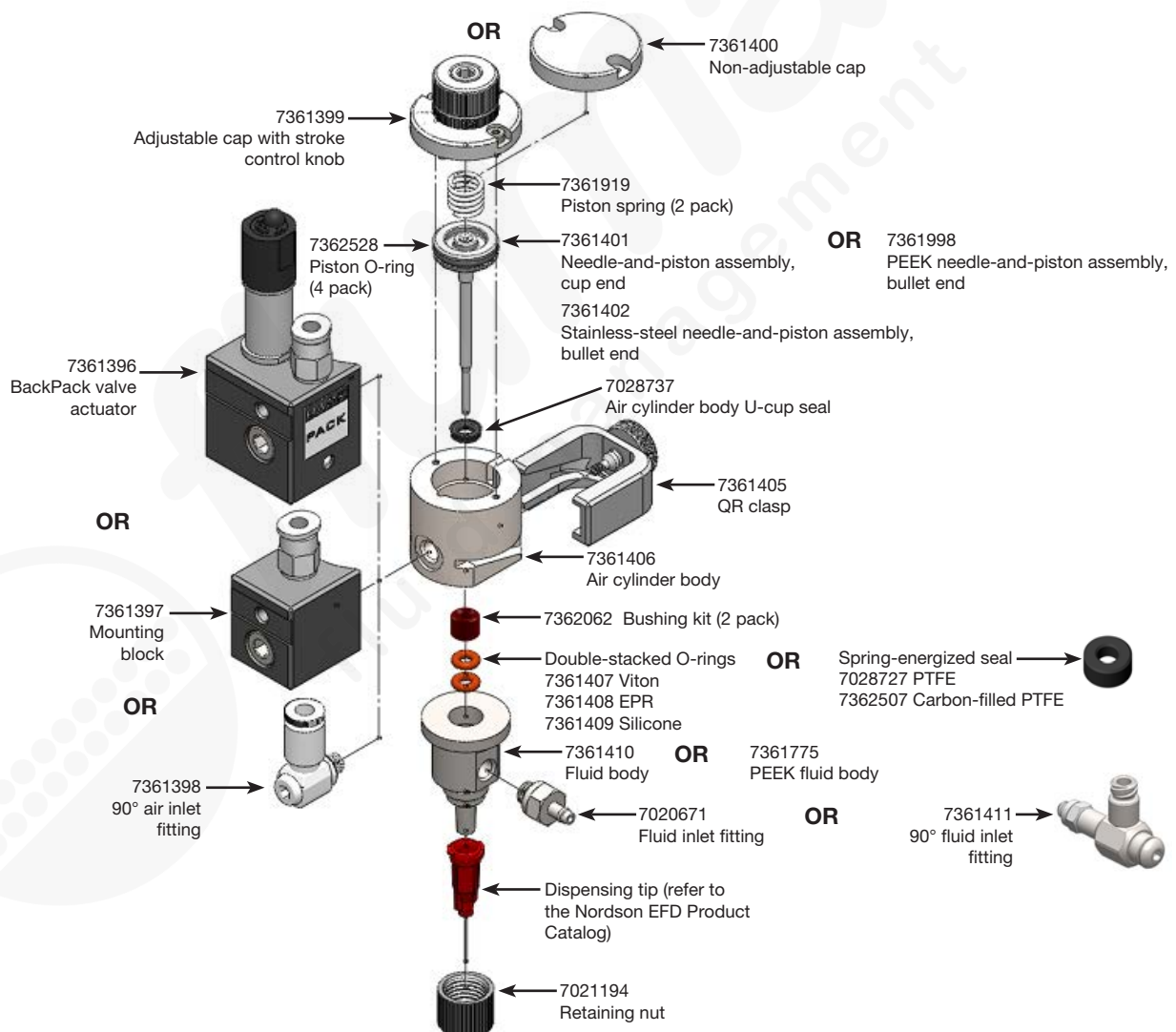

Replacement Parts (continued)

BackPack Valve Actuator

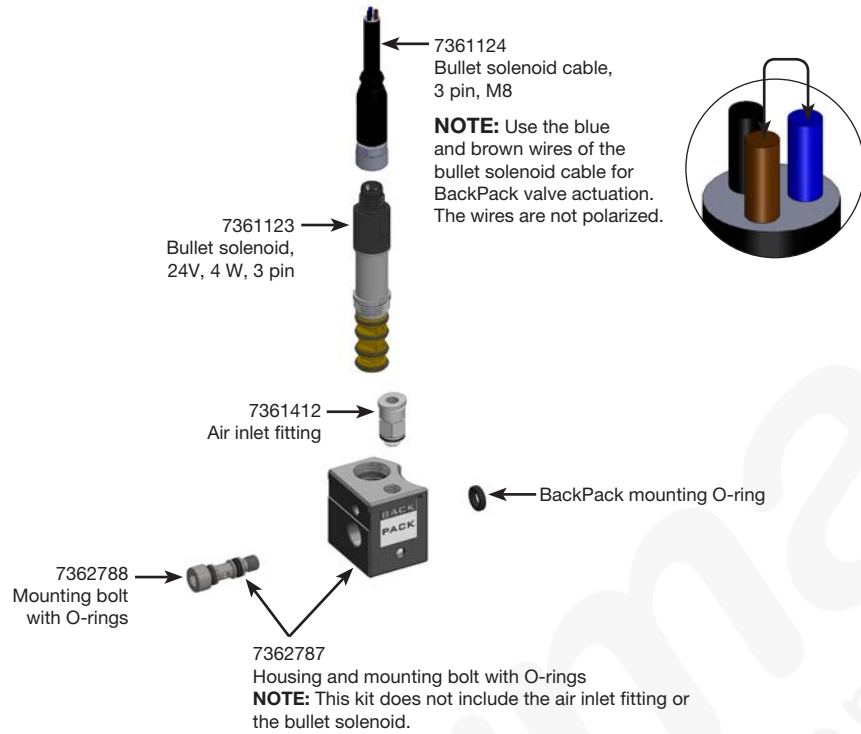

Mounting Brackets



Troubleshooting

Problem	Possible Cause	Corrective Action
No fluid flow	Valve operating air pressure too low	Increase air pressure to 4.8 bar (70 psi) minimum.
	Reservoir air pressure too low	Increase the air pressure to the reservoir.
	Needle stroke adjusted to the closed position	Adjust the needle stroke. Refer to “Dispensing Tip Change and Valve Stroke Calibration” on page 13.
	Clogged fluid body or output tip adapter	Clean the valve. Refer to “Cleaning the Valve” on page 15.
	Dispensing tip retaining nut not tightened enough to unseat the needle	Tighten the dispensing tip retaining nut.
Steady drip	Needle damaged	Remove the tip adapter/seat assembly. Clean and inspect the needle. Replace the dispensing tip.
Fluid leaks from drain hole	Worn O-ring seals	Replace the double-stacked O-rings. Refer to “Cleaning the Valve” on page 15.
Inconsistent deposit size	Air pressure controlling the valve and/or supplying the reservoir fluctuating or valve operating pressure less than 4.8 bar (70 psi)	Make sure the air pressures are constant and the valve operating pressure is 4.8 bar (70 psi).
	Valve open time inconsistent	The time the valve is open must be constant. Make sure the valve controller is providing a consistent output.
Stroke control knob rotates freely	Over-tightened stroke control knob damaged the internal stop assembly, or a stuck knob forced to turn	Replace the adjustable cap, which includes the stroke control assembly.
Stroke control knob stuck	Knob over-tightened in either the open or closed direction	<p>Determine whether the knob is stuck in the fully open or fully closed position by actuating the valve.</p> <p>NOTE: When the valve is fully closed, the needle does not move when the valve is actuated. When the valve is fully open, the needle moves when the valve is actuated.</p> <p>If the valve does not actuate, the knob is stuck fully closed. Turn the knob counterclockwise to correct the problem.</p> <p>If the valve actuates, the knob is stuck fully open. Turn the knob clockwise to correct the problem.</p> <p>Once the knob is turning freely, recalibrate if needed. Refer to the calibration steps under “Dispensing Tip Change and Valve Stroke Calibration” on page 13.</p>

Continued on next page

Troubleshooting (continued)

Problem	Possible Cause	Corrective Action
BackPack valve actuator not cycling	No air supply	Confirm that the main air supply is ON.
	Cable wires loose or damaged	Inspect the cable wires for loose connections or damage and tighten connections or repair damage.
	Bullet solenoid cable wires incorrectly connected	Ensure that the blue and brown cable wires are connected for BackPack valve actuation. The wires are not polarized.
	Failed bullet solenoid	Replace the bullet solenoid. Refer to “Replacing the Bullet Solenoid on the BackPack Valve Actuator” on page 17.
Air leaks from BackPack valve actuator housing	Loose housing	Tighten the housing.
	Damaged mounting bolt O-ring seals	Check the mounting bolt for damaged O-ring seals. Replace if needed.
	Damaged bullet solenoid O-rings	Check the bullet solenoid for damaged O-rings. Replace if needed.
BackPack actuator bullet solenoid not actuating	Bullet solenoid cable wires broken	Replace the bullet solenoid. Refer to “Replacing the Bullet Solenoid on the BackPack Valve Actuator” on page 17.
	Bullet solenoid cable wires incorrectly connected	Ensure that the blue and brown cable wires are connected for BackPack valve actuation. The wires are not polarized.

NORDSON EFD ONE YEAR LIMITED WARRANTY

Nordson EFD products are warranted for one year from date of purchase to be free from defects in material and workmanship (but not against damage caused by misuse, abrasion, corrosion, negligence, accident, faulty installation or by dispensing material incompatible with equipment) when the equipment is installed and operated in accordance with factory recommendations and instructions. Nordson EFD will repair or replace free of charge any part of the equipment thus found to be defective, on authorized return of the part prepaid to our factory during the warranty period. In no event shall any liability or obligation of Nordson EFD arising from this warranty exceed the purchase price of the equipment. This warranty is valid only when oil-free, clean, dry, filtered air is used.

Nordson EFD makes no warranty of merchantability or fitness for a particular purpose. In no event shall Nordson EFD be liable for incidental or consequential damages.

